



*IPI's Guide to:*

# **Sustainable Preservation Practices** *for managing storage environments*





Funded by the National Endowment for the Humanities, Division of Preservation and  
Access, Education & Training Grant Program

January 2010—December 2013

Image Permanence Institute, Rochester Institute of Technology

70 Lomb Memorial Drive, Rochester, New York 14623

585-475-5199 [www.imagepermanenceinstitute.org](http://www.imagepermanenceinstitute.org)

This project was designed to enable collections care staff in cultural institutions to avoid risks to collections while they support sustainability efforts and pursue opportunities for energy cost reduction.

Visit [www.ipisustainability.org](http://www.ipisustainability.org) to learn more.

**Project Coordinator:** Patricia Ford

**Content:** Patricia Ford, Peter Herzog, Jeremy Linden, James Reilly, and Kristin Smith

**Design & Editing:** Lauren Parish

Version 2.0 – July 2012

**The Image Permanence Institute receives funding from:**

The Andrew W. Mellon Foundation

The Institute for Museum and Library Services

The National Endowment for the Humanities

# CONTENTS

Introduction.....	1
Foreword .....	5

## Section I: What You Need to Know

### DEFINE AN OPTIMAL AND SUSTAINABLE PRESERVATION ENVIRONMENT

---

#### CHAPTER 1:

The Basic Elements of the Environment and Their Effect on Material Decay.....	7
IA: Environmental Basics – Defining Temperature, Relative Humidity, and Dew Point.....	7
IB: Collection Basics – Defining Basic Material Types.....	9
IC: Deterioration Basics – Defining Types of Environmentally-Induced Decay .....	10
ID: Risks & Benefits: Understanding How the Environment Determines the Rate of Material Decay ...	12

#### CHAPTER 2:

The Factors that Shape the Storage Environment.....	16
2A: The Local Climate .....	16
2B: The Building Envelope .....	20
2C: Mechanical Systems.....	22
2D: Energy Use in the Storage Environment.....	28
2E: Institutional Stakeholders.....	31

## Section 2: What You Need to Do

### ACHIEVE THE LEAST RISK TO COLLECTIONS AND THE BEST ENERGY SAVINGS POSSIBLE

---

#### CHAPTER 3:

Document the Current Storage Environment.....	33
3A: Collect Appropriate Data.....	34
3B: Environmental Monitoring Tools .....	35
3C: Determine Where to Locate Environmental Monitors .....	37
3D: Additional Considerations when Selecting Environmental Monitoring Devices.....	38

#### CHAPTER 4:

Document Each Storage Facility's Mechanical System.....	38
4A: Create Floor Plans Indicating Collection Areas and HVAC Zones .....	39
4B: Create Schematic Diagrams to Document the Mechanical System.....	41
4C: Identify Heat Loads and Sources of Moisture .....	44

---

CHAPTER 5:	
Understand the Role of Dew Point.....	46
5A: Managing Dew Points in Practice .....	47
5B: Understand the Moisture Content of the Air.....	48

CHAPTER 6:	
Analyze Collected Data .....	53
6A: Use Environmental Data to Manage the Environment for Preservation .....	53
6B: Use IPI’s Preservation Metrics™ to Analyze the Risk of Material Decay .....	54
6C: Data Analysis and Mechanical System Performance .....	59

## Section 3: Institute Sustainable Preservation Practices

### MAINTAIN AN OPTIMAL AND SUSTAINABLE PRESERVATION ENVIRONMENT

---

CHAPTER 7:	
Create an Environmental Management Team .....	64
7A: Develop an Effective Environmental Management Team.....	65
7B: Define the Broad Responsibilities of the Environmental Management Team .....	67

CHAPTER 8:	
Specific Activities of the Environmental Management Team.....	68
8A: Define the Optimal Storage Environment for your Institution in Six Steps .....	68
8B: Maintain Optimal Storage Environments in your Institution .....	71

CHAPTER 9:	
Investigate Opportunities for Energy Savings .....	73
9A: Energy Saving Suggestions for Class One, Two, and Three Buildings.....	73
9B: Energy Saving Suggestions for Class Four and Five Buildings.....	75
9C: Operational Energy Saving Opportunities to be Investigated.....	78

## Section 4: Additional Information

### GUIDE YOUR INSTITUTION TOWARD SUSTAINABLE PRESERVATION PRACTICES

---

Annotated Bibliography.....	81
Influence of Local Climate on HVAC System Exercise with Regional Examples .....	92
HVAC System Documentation Worksheet - Part 1 .....	103
HVAC System Documentation Worksheet - Part 2 .....	104
HVAC System Documentation Worksheet - Part 3 .....	105
NEH Grant Opportunities .....	106
IPI’s Environmental Management Products .....	109

# INTRODUCTION

## MAKING CULTURAL INSTITUTIONS SUSTAINABLE

An optimal preservation environment is one that achieves the best possible preservation of collections with the least possible consumption of energy, and is sustainable over time.

In 2009, the National Endowment for the Humanities (NEH) provided funding to the Image Permanence Institute (IPI) for an Education & Training series titled Sustainable Preservation Practices for Managing Storage Environments. This funding allowed IPI to present information about defining and achieving an optimal and sustainable preservation environment to hundreds of institutions around the country in 2010 and 2011 through a series of workshops and webinars. Our primary goal was to provide information, strategies, and tools that would enable staff in collecting institutions to make informed, strategic decisions regarding sustainability that would result in responsible collections care, energy cost savings, and carbon footprint reduction. The workbook created by IPI for the project has evolved into this publication.

During the same period, IPI received funding for two research projects related to sustainability. The NEH Research & Development Program funded Methodologies for Sustainable HVAC Operation in Collection Environments, an investigation designed to determine the best methods to ensure that library, archive, and museum collections are not harmed by short-term environmental fluctuations (temperature and relative humidity setbacks) made in the name of reducing energy costs. The Institute of Museum & Library Services (IMLS) granted IPI a Research & Demonstration National Leadership Grant titled Research on Energy Saving Opportunities in Libraries to investigate whether energy usage can be significantly reduced by carefully monitored and risk-managed shutdowns of air handling units (AHUs) during unoccupied hours in selected research library storage spaces.

These projects will produce two additional publications, one focused on the optimal management of temporary HVAC shutdowns, and another on the best methodology for temperature and humidity setbacks. The IMLS energy saving opportunities project publication and associated web-based resource will document the project's research methodology and results. This guide to shutdowns is expected to be available in the Fall/Winter of 2013. At the close of the NEH-funded sustainable HVAC operation project IPI will publish *Methodologies for Sustainable HVAC Operation in Collection Environments* which will include step-by-step guidance on HVAC setbacks for collecting institutions. This field guide will be available by the winter of 2013-14.

This Guide to Sustainable Preservation Practices and the two publications described above are designed to help institutions maintain the best climate for preservation with the least consumption of energy.

*"IPI is the most innovative and leading organization addressing environmental needs for collections in the museum, library, and archival fields."*

*Lawrence L. Reger, President, Heritage Preservation*

*"IPI's research and contributions in the area of collections and archives care are well known throughout the preservation field. They have undertaken numerous solid and well thought out research programs, nationally and internationally, which have resulted in useful tools and data for those charged with conservation of cultural heritage."*

*Jerry Podany, Senior Conservator of Antiquities, J. Paul Getty Museum, and President of the International Institute for Conservation*

Based on the success of the first program, NEH provided funding for Sustainable Preservation Practices for Managing Storage Environments—Series II. Four workshops will take place between August and November 2012, followed by nine topical webinars in the first half of 2013.

Years of research on climate and material decay changed the way we understand the effect of the environment on collection materials and opened up the range of acceptable temperature and relative humidity settings. Updated mechanical system operating standards and new methods of data analysis led the way to opportunities for reductions in energy use and related cost savings. IPI's initial series of Sustainable Preservation Practices workshops and webinars presented this information to several hundred individuals including collection care and preservation staff, facility managers, administrators, and students. Interest in the information, tools, and operational strategies presented in this series remains high and IPI is committed to the development and deployment of sustainable preservation practices and to the creation of useful tools and publications that serve the field of preservation.

Much of IPI's research on environmental management has been funded by the National Endowment for the Humanities (NEH). The development of IPI's Preservation Metrics™, algorithms that analyze temperature and RH over time and evaluate the impact of environmental conditions on collection materials, as well as IPI's hardware and software programs for environmental management were made possible by NEH support. IPI has also received major support for its research from the Institute for Museum and Library Services (IMLS) and the Andrew W. Mellon Foundation.

## Making Cultural Institutions Sustainable

Collecting institutions face difficult choices as they respond to apparently conflicting mandates to lower operating costs, achieve sustainability goals, and preserve collections. The cost of energy used by cultural institutions to heat, cool, and dehumidify remains a formidable drain on institutional budgets. At the same time, collecting institutions have an obligation to provide the best stewardship possible to the object and information resources in their collections. Allowing collections to deteriorate in sub-optimal environmental conditions would be a significant loss to the humanities and to society in general.

Areas dedicated to collection storage typically receive conditioned air twenty-four hours a day, seven days a week, and are

*"For more than 50 years conservators around the world have sought to prevent damage to the varied objects in their collections by observing a uniform climate-control mantra: Keep everything in the museum at approximately 70 degrees Fahrenheit and 55 percent relative humidity. Since the 1970s that goal has increasingly been achieved with the help of mechanical HVAC systems, which typically cope with unforeseen events by working overtime. But as museum budgets shrink, energy costs spiral, and gradual climate changes make the traditional HVAC system more costly to maintain, conservators and other museum experts are rethinking this model."*

*Carol Kino, "Keeping Art, and Climate, Under Control," <http://www.nytimes.com/2009/04/05/>*

maintained at more stringent temperature and humidity conditions than other spaces. As a result, these spaces consume more energy than other areas. Performance measurements by the energy consulting firm Herzog/Wheeler & Associates (the Image Permanence Institute's partner in several research and consulting projects) indicate that a 10,000 square foot collection storage area costs between \$20,000 and \$50,000 per year to condition. As a result, cultural institution facility managers and administrators are asking collection care staff to consider energy-saving alterations to the operation of storage area HVAC systems.

Determining if proposed energy-saving strategies are viable requires thoughtful consideration of building design, mechanical systems, and collection vulnerabilities. While some options are not viable, others could reduce energy consumption by 10% to 30%, without posing significant risk to collection preservation.

Beyond the strain on budgets from energy costs, concern has grown over the burning of fossil fuels to power HVAC systems, which adds significantly to the production of atmospheric carbon dioxide. Many institutions are committed to integrating sustainable energy use practices into all major operations. However, these goals need to be balanced with the responsibility for long-term care and preservation of collections. Unfortunately, in many cases neither the facilities staff nor the collection care staff feels they have the expertise or tools to properly evaluate the impact on long-term preservation of energy reduction strategies such as night and weekend setbacks, AHU shutdowns, or significant changes in temperature and relative humidity settings. Collection care staff fear that arbitrary changes in climate settings will undo years of hard-won gains, and they are very anxious to avoid the perception that controlled conditions are frivolous and unnecessary. Facilities staff are convinced that cost savings are possible if collection staff would ease their requirements. The lack of specific guidelines and methods to avoid risks to collections while taking advantage of opportunities for cost reductions and sustainability gains defined the need for IPI's initial Sustainable Preservation Practices series of workshops and webinars.

It is very important that collections care and facilities staff work together to manage the environment to reach both preservation and energy saving goals. A joint learning experience, ideally with administrative support, is the best way to build a shared sense of direction and purpose. To truly achieve an optimal and sustainable environment these individuals need to communicate effectively, work cooperatively, and become partners in environmental management.



## How to Use This Guidebook

### **This guidebook is divided into four primary sections:**

- **Section One** focuses on what you need to know about the environment, its effect on material decay and the primary factors that shape the storage environment. Use this section as an introduction or a refresher course depending on your background.
- **Section Two** details what you need to do to accurately document both the storage environment and associated climate control systems and how to use this knowledge to effectively analyze risk and improve preservation quality.
- **Section Three** was designed to guide and focus environmental management activities and highlight opportunities for energy savings and sustainable practices.
- **Section Four** includes additional guidance and information for your use.

The goal is an optimal preservation environment—one that achieves the best possible preservation of collections with the least possible consumption of energy, and is sustainable over time.

If your institution has taken steps to reduce energy costs by making changes that effect the storage environment, we would like to know about it. Please tell us what steps were taken, how those decisions were made, and what the impact has been. Email Patricia Ford at [pafpph@rit.edu](mailto:pafpph@rit.edu).

# FOREWORD

## DEVELOPMENT OF NEW ENVIRONMENTAL STANDARDS

A great deal has been learned in recent years about managing the storage environment in collecting institutions. The accepted norm—that temperatures should be steady and unwavering at human comfort levels, and that short-term fluctuations in relative humidity matter more than long-term trends—is now regarded by preservation scientists as outmoded and counter-productive. Environments are complicated. The simple notion of setting targets for an ‘ideal’ environment and watching for daily or weekly excursions is the wrong approach. Even the greenest of buildings can’t make flat lining at 70°F and 50% RH sustainable. As the current economic situation and related budgetary problems force cost reductions, collecting institutions need a new management approach in order to navigate between fiscal realities and effective preservation strategies.



A close reading of the literature of conservation will reveal that the creators of the unwavering 70°F/50% RH recommendations regarded their suggestions as provisional pending closer study. The evolution away from such simple ideas and toward a more modern view incorporates research undertaken over the last twenty-five years. Modern thinking holds that all environments are compromises among various agencies of decay. Thanks to this research, we know more about the specifics of these agencies.

The Smithsonian's Museum Conservation Institute has done a great deal to clarify how moisture content affects the mechanical properties of cultural heritage objects. Their work shows that extremes of dryness and dampness pose the greatest risk of physical damage. And that statement contains one of the most significant differences between old thinking and new thinking. We're now concerned much more with what poses the greatest threat (that is, in identifying the circumstances we need to avoid) than we are with articulating an ideal.

Through years of massive accelerated aging projects, including research at the Library of Congress and at the Image Permanence Institute (IPI), preservation science laboratories have explored and clarified how materials such as plastics, dyes, paper, leather, and textiles are at risk due to spontaneous chemical change—decay that we might call ‘natural aging.’ This kind of deterioration is long-term and depends on the integral over time of temperature (thermal energy) and RH (moisture content of the objects).

The current understanding about environment standards is that there is no such thing as a “one size fits all” standard that is possible and that each institution must figure out what is best for each storage location

based on a holistic approach that includes the most significant vulnerabilities of the stored materials, the capabilities of the HVAC system, the external environment, and the limitations imposed by the building construction.

The Museum Microclimates conference held in Denmark in 2007 included many papers addressing the validity of strict environmental standards and the move toward a more holistic view of risk analysis. The development of new standards for storage and exhibition environments is reflected in guidelines recently developed and published by the Canadian Conservation Institute. On their website, the introduction to their Environmental Guidelines for Museums describes their approach as “a departure from earlier more traditional thinking about museum environments, which called for stringent control of RH and temperature.” CCI also notes that “it is neither economical nor environmentally acceptable to have very tightly controlled conditions if they are not necessary.” The Getty Conservation Institute recently referenced a “new interdisciplinary initiative that will focus on the research and development of sustainable environmental control and management strategies for collections in museums, libraries, archives, and other repositories.”

IPI has been active in the development of new environmental standards for over fifteen years. Working in partnership with the energy management consulting firm Herzog/Wheeler & Associates, IPI has taken its experience with material preservation research and environmental assessment into the field to explore and develop a cross-disciplinary approach between building engineers, facility managers, collection staff, and preservation specialist.

IPI and Herzog/Wheeler call this process ‘optimization’—meaning that human comfort, energy and fossil fuel consumption, and preservation quality are all measured, brokered and discussed, and ultimately, an optimal combination of each is achieved. This vision can work, but it cannot be fully realized without a clear and accurate understanding of material decay, the realities of the storage environment, the role of local climate, the building envelope, and the basic functions of the mechanical system. No one is a master of every aspect, but a team of shareholders including collection care staff, facility managers and administrators, sharing their particular knowledge, can implement changes that both save energy and protect collections.

*An examination of the history and development of recommendations for the climate in museums reveals that there was minimal scientific support for the values and ranges that were selected. The small basis of research that existed was often extended to materials or objects to which it did not apply; decisions that were merely best guesses based on minimal evidence became set in stone; and the rationale for many decisions seems to have been forgotten or twisted around. It is only relatively recently that research has provided a general scientific basis for determining appropriate values for the museum climate, especially the range in which temperature and relative humidity can be safely allowed to vary. Because the results of this research differed from what had become climatic dogma, it was criticized by some in the field. However, the results have stood up, with no substantive challenge to the data or conclusions, and are increasingly widely accepted.*

*David Erhardt, Charles S. Tumosa and Marion F. Mecklenburg, “Applying Science to the Question of Museum Climate,” Proceedings from Museum Microclimates, T. Padfield & K. Borchersen (eds.) National Museum of Denmark, 2007 ISBN 978-87-7602-080-4*

# SECTION 1: WHAT YOU NEED TO KNOW

## DEFINE AN OPTIMAL AND SUSTAINABLE PRESERVATION ENVIRONMENT

### Section One includes two chapters:

- Chapter 1: The Basic Elements of the Environment and Their Effect on Collection Materials
- Chapter 2: The Factors that Shape the Storage Environment

These chapters introduce the various elements that create the storage environment and the way that materials in the collection respond to those elements. With an understanding of these fundamentals it is possible to define an optimal and sustainable environment for the preservation of institutional collections.

Section Two – What You Need to Do – will cover activities involved in achieving an environment with the least risk to collections and the best energy savings possible.

## 1

### CHAPTER 1: The Basic Elements of the Environment and Their Effect on Material Decay

Long-term preservation of the collection materials requires an understanding of the elements that make up the environment (temperature, relative humidity, dew point), the elements that make up your collection (organic, inorganic, and composite materials), the basic modes of deterioration (chemical, biological and mechanical), and the basics of material decay (reacting to heat and moisture).

#### 1A Environmental Basics – Defining Temperature, Relative Humidity, and Dew Point

While there are a number of factors that can be included in a broad concept of storage environment, this guidebook deals primarily with the environment. Light, air pollution, radiation, and vibration – when present – are important and deserving of attention. However, temperature and relative humidity are the most fundamental factors to consider in environmental management. They are always present and they have a direct affect on the rate of decay in nearly all materials. Research has also shown how important understanding the role of dew point is in managing the environment for preservation. (See Section 2, Chapter 5—Understand the Role of Dew Point).

## Temperature

HEAT IS A FORM OF ENERGY THAT DRIVES CHEMICAL REACTIONS

Temperature is the measure of the motion of molecules in a material. As temperature increases the molecules move faster and collide with greater force, increasing the chances for a chemical reaction to occur. At higher temperatures, biological activity also increases as insects eat more and breed faster, and mold growth increases. This is why colder temperatures are often recommended for collection storage—cooler temperatures mean a slower rate of chemical decay. Not too cold, however—at low temperatures some materials contract and may become brittle.

## Relative Humidity (RH)

REPRESENTS HOW SATURATED THE AIR IS WITH WATER VAPOR AND DETERMINES THE AMOUNT OF WATER CONTAINED WITHIN COLLECTION OBJECTS

Water vapor forces its way into and out of moisture absorbing materials until equilibrium – a balance between interior and exterior moisture levels – is established. Most organic and some inorganic materials are hygroscopic – they absorb and release water depending on the relative humidity of the surrounding air. As the RH in the space increases, objects absorb more water; as it decreases they release moisture. Mold growth can become a problem at 65% RH and above. At low humidity levels, wood and ivory will shrink, warp and crack; leather and photo emulsions will shrink, stiffen, crack and flake; paper, fibers and adhesives will desiccate.

*IPI's Dew Point Calculator is available for free at:*

*<http://www.dpcalc.org>*

*You can explore various combinations of temperature, relative humidity, and dew point and compare the relative preservation quality of each environment.*

## Dew Point

A MEASURE OF THE ABSOLUTE AMOUNT OF WATER IN THE AIR

Dew point is also the temperature at which the air cannot hold all the moisture in it and water condenses. As air is circulated into and around a building, its absolute moisture content—and therefore its dew point—does not change unless it is humidified or dehumidified. In other words, unless the mechanical systems add or remove water from the air, the outdoor dew point and the indoor dew point will be the same.

## Temperature, Relative Humidity, and Dew Point are Interrelated Variables

The dew point determines what combinations of temperature and RH will be possible in the storage environment. At a constant dew point, when the temperature goes up, the RH goes down and when the temperature goes down, the RH goes up. Therefore, the dew point is responsible for determining which temperature setting will give you which RH. Institutions that try to improve conditions by lowering storage temperatures without carefully watching the resulting RH may find that the moisture level is much too high for safe storage of vulnerable collections. You can explore this relationship using <http://www.dpcalc.org>.

## 1B Collection Basics – Defining Basic Material Types

Most of us look at the collections in our care in terms of object type—paintings, furniture, documents and manuscripts, fossils, etc. When managing the environment for preservation, it is important to understand the collections as materials, as the substance that they are made from. This perspective makes it easier to understand the reaction of various collection types to the storage environment.

### Material Types

Museum objects are often divided into three material-type categories: organic, inorganic, and composite. Understanding the properties of each of the materials in these categories will help you understand how they react to the environment.

#### ORGANIC MATERIALS

Organic objects are made from materials that were once living — plants or animals. These materials include wood, paper, textiles, leather and skins, horn, bone and ivory, grasses and bark, lacquers and waxes, plastics, some pigments, shell, and biological natural history specimens. Organic materials are processed in a multitude of ways to produce the objects that come into your collections.



Organic materials share the following common characteristics:

- They contain the element carbon
- They are combustible
- They are sensitive to light
- They are a source of food for mold, insects, and vermin
- They are made of complicated molecular structures that are susceptible to deterioration from extremes and changes in relative humidity and temperature
- They absorb water from and emit water to the surrounding air in an ongoing attempt to reach an equilibrium (hygroscopic)

#### INORGANIC MATERIALS

Inorganic objects have a geological origin. Inorganic materials include metals, ceramics, glass, stone, minerals, and some pigments. As with organic objects, inorganic materials are processed in a variety of ways to produce the objects found in your collections.



Inorganic materials share the following common characteristics:

- They have undergone extreme pressure or heat
- They are usually not combustible at normal temperature
- They can react with the environment to change their chemical structure (for example, corrosion or dissolution of constituents)
- They may be porous (ceramics and stone) and will absorb contaminants (for example, water, salts, pollution, and acids)
- They are not sensitive to light, except for certain types of glass and pigments

### COMPOSITE OBJECTS

Composite or mixed media objects are made up of two or more materials. For example, a painting may be made of a wood frame and stretcher, a canvas support, a variety of pigments of organic and inorganic origin, and a coating over the paint. A book is a composite of several materials such as paper, ink, leather, thread, and glue.

Depending on their material makeup, composite objects may have characteristics of both organic and inorganic objects. The individual materials in the object will react with the environment in different ways. Also, different materials may react in opposition to each other, setting up physical stress or causing chemical interactions that cause deterioration.



## 1C Deterioration Basics – Defining Types of Environmentally-Induced Decay

Deterioration is a natural process by which an object reaches a state of equilibrium with its immediate environment. The primary types of deterioration detailed here include chemical decay or natural aging, biological deterioration, and mechanical or physical decay. Deterioration is inevitable, but the rate of physical and chemical change in an object can be slowed if the storage environment is properly managed.

### Chemical Decay – a chemical reaction that causes changes in an object at the atomic and molecular level

A wide variety of decay manifestations in collection objects are caused by chemical reactions. Examples of chemical decay include metal corrosion, deterioration of pigments, staining by acidic materials, and embrittlement of pulp papers and textiles. Both moisture and temperature play a role in chemical decay. For organic materials such as paper, vellum, wood, textiles and plastics, chemical decay is ongoing and spontaneous. For this reason, chemical decay is sometimes



referred to as “natural aging”. Preservation benefits accrue as objects become cooler and drier because decreased thermal energy slows the rate of chemical reactions. Dry conditions starve chemical reactions of the moisture needed for the reactions to take place.

Corrosion is a form of chemical decay found most commonly in metals. Corrosion results from high humidity, high temperature, and atmospheric pollutants. Examples of corrosion include silver tarnishing and rust damage. Corrosion can be concentrated to form a pit or crack, or may extend across a wide area. Corrosion is primarily the result of moisture in the air, and begins at relative humidity levels of about 55% or greater. However, the presence of pollution, dust, salts, oils or active corrosion can allow metal corrosion to occur at lower humidity levels.



## Biological Decay – caused by the attack of biological organisms

Biological decay is driven by heat and especially by moisture. Organic materials are particularly susceptible. In practice, mold and insects pose the most acute biological preservation risks. Mold spores are always



present in the atmosphere and just require a sustained high RH for a certain period of time to propagate. Active mold produces enzymes that can digest organic materials such as paper and textiles, weakening or destroying them. Colorful blooms can cause stains that cannot be removed. Generally, maintaining RH conditions below 65% eliminates any risk from mold growth. Insect infestations, which can result in damage or loss due to feeding by insects or their larvae, are minimized by keeping RH below 50% and temperatures cool.

## Mechanical Decay – a change in the physical structure of an object

Mechanical decay includes softening of plastics and waxes, cracking and buckling of wood, warping, and delamination. This type of decay can be caused by physical force or mishandling, but may also be the result of changes in the environment that lead to physical stresses in an object. Environmentally-induced mechanical decay is primarily driven by extremes of RH, although temperature extremes can affect the degree of risk if prevailing conditions are cold enough to cause brittleness or dry enough to cause cracking.



Estimating the degree of risk of mechanical decay from improper RH conditions is difficult to generalize because the construction details of composite objects have a strong influence on their behavior. Various materials will respond differently and cause stress between components of an object. Excessive dampness can result in differential expansion, sagging, warping, and permanent deformation. Excessive dryness leads to contraction, brittleness, cracking and tearing. Risk also results from repeated changes in moisture content that cause slow progression of micro-cracks and other forms of “fatigue” in materials.



## 1D Risks & Benefits: Understanding How the Environment Determines the Rate of Material Decay

The preservation quality of an environment is best judged in terms of relative risks and benefits to the collections in the space. Because decay occurs through different mechanisms – chemical, mechanical, and biological – conditions that bring benefits for one decay mechanism may bring increased risk with another. For example, extreme dryness will eliminate corrosion risk in metals and slow the natural aging rate in organic materials. However, for some objects, such as vellum-bound books, dryness presents an unacceptable risk of shrinkage and brittleness, especially when handled. You'll need to find the right balance of risk and benefit for the materials in your collection.

*The risks to collections from theft, fire, flood, or other catastrophic events are always considered and steps are put into place to protect and insure against these risks. Shouldn't the risk to collections from the storage environment demand the same consideration?*

### The Effect of Temperature on Material Decay

- At high temperatures (generally above 75°F) chemical reactions increase and the rate of “natural aging” increase. Magnetic media, plastics, film, leather, rubber, dyes, and acidic paper are particularly vulnerable. Watch for deformation, sagging, melting, stickiness, and adhesive failure.
  - Magnetic media may disintegrate or be unplayable.
  - Color prints may fade, other organic materials may discolor.
  - Cellulose nitrate will disintegrate.
  - Acetate film and early plastics will shrink, crack, and distort.
  - Elastic polymers like foam and rubber become brittle or sticky.
  - Acidic paper will become brittle.
- Biological activity increases at warmer temperatures—insects will eat more and breed faster, mold will grow faster within certain temperature ranges.
- In general low temperatures are good for preservation, provided that they don't result in dangerously high RH.
- Some materials are sensitive to low temperatures (below 50°F), particularly polymers found in modern paints and coatings, vulnerable rubber and plastic objects. Temperatures that are too low can cause desiccation, which results in fractures in paints, adhesives, and other polymers.
- Wide and frequent fluctuations in temperature can cause fractures and delamination in brittle, solid materials. Furniture, ivory, and oil paintings are particularly vulnerable.

## The Effect of Relative Humidity on Material Decay

- Dampness (relative humidity over 65%) can result in mold, metal corrosion, and dye bleed in vulnerable collections. High humidity also causes swelling and warping of wood and ivory, buckling of paper, softening of adhesives, and an increase in biological activity.
- Relative humidity above 0% supports hydrolysis that gradually disintegrates and discolors organic materials, especially materials that are chemically unstable such as pulp paper and magnetic media.
- Dryness (low relative humidity) will cause organic materials to shrink, warp and crack; papers and textiles can become brittle.
- Fluctuating RH will shrink and swell unconstrained organic materials, crush or fracture constrained organic materials, cause layered organic materials to delaminate and/or buckle, and loosen joints in organic components.

## When Do Collections Feel Changes in the Environment?

The next issue to consider is how long it takes for collection objects to equilibrate (or adjust) to any changes in the environment. Do objects react differently to changes in temperature than they do to changes in relative humidity? What factors determine the rate of equilibration?

### THERMAL EQUILIBRATION — ADJUSTING TO TEMPERATURE CHANGE

Material response to changes in temperature, called thermal equilibration, occurs relatively quickly compared to the response to changes in RH. **Most materials will adjust to the temperature of a new environment in a matter of hours** (See Section 4 - Annotated Bibliography: Material Response and Behavior, p.84 for more information). When researchers at IPI exposed a variety of photographic materials to temperature changes, they found that most fully equilibrated to the new temperature conditions within 6 to 12 hours. Adjustment time varied according to the material and its configuration. Despite these differences, all the tested materials—motion-picture film, acetate sheet films, and resin-coated photographic prints—demonstrated a relatively fast rate of thermal equilibration.

The time needed to adjust to a new temperature condition is influenced by the amount of exposed surface area and the thermal mass of the object. Objects with a large percentage of their surface area exposed to a new environmental condition will equilibrate faster than objects with less. In other words, a single object on a shelf will equilibrate faster than an object in the middle of a stack of objects. The thermal mass of the object has a similar effect on equilibration time. The greater the thermal mass, the more time it takes for energy to penetrate to the object's core. For most collection objects however, thermal equilibration requires just a few hours.

Because enclosures and housings offer physical protection for the object, you might assume that the enclosures also protect the objects from changes in temperature. However, while some enclosures may act as a moisture barrier, research shows that enclosures do not significantly block the transfer of heat or reduce the time needed to adjust to new temperature conditions. Studies also show that the extent

of the temperature change does not alter the time needed for full thermal equilibration. Researchers at IPI enclosed a stack of photographic prints in a cardboard box. The stack was then exposed to three different temperature changes: raised from 3°F to 70°F; raised from 41°F to 70°F; and cooled from 122°F to 70°F. In each case, it took the stack approximately five hours to equilibrate to the new temperature. Although the first test group had to warm up significantly more (67°) than the second group (29°), the time to reach equilibration was the same. The direction of temperature change did not significantly alter the time needed for equilibration time either—when the stack was cooled from 122°F to 70°F the time to equilibrate was the same.

**It is important to remember that the amount of heat in the environment is usually more significant to preservation than the fluctuations in temperature. The higher the temperature, the faster chemical reactions will occur; the lower the temperature, the slower chemical reactions will occur.**

**CONCLUSION:** Sustained high temperatures have a much more significant impact on the stability of collection materials than do temporary spikes or wide fluctuations of temperature.

#### MOISTURE EQUILIBRATION – ADJUSTING TO CHANGES IN RELATIVE HUMIDITY

Material response to changes in relative humidity, called moisture equilibration, occurs relatively slowly compared to the response to changes in temperature. **All of the materials tested by IPI (without enclosures) reached moisture equilibration in a matter of days or weeks, as opposed to hours for thermal equilibration.** The process of moisture equilibration is more complex than that of thermal equilibration. Several variables determine the length of time it takes an object to equilibrate—including its size, the amount of surface exposure, object enclosures and temperature. Finally, there is more variation in the capacity of individual objects to control moisture equilibration than thermal equilibration.

Only hygroscopic materials—organic materials that naturally contain water—are susceptible to moisture equilibration. These materials absorb or release water to equilibrate with the relative humidity of the environment. Non-hygroscopic materials are not absorbent by nature and have no moisture to release. They therefore don't equilibrate with changes in the environment's moisture, however they may be affected by moisture in other ways, such as corrosion of metal.

As the moisture content of the air increases, the material begins to absorb the increased moisture. The moisture travels from the outside of the object inward, affecting the edges and the top of the object before reaching the core. When the relative humidity of the environment decreases, the material releases moisture into the environment in order to reach a balance. The moisture travels from the inside of the object outward towards the surface. This exchange of moisture is continuous until the object has reached moisture equilibrium with the environment.

Moisture equilibrium is not attained instantly. It takes time for the object to absorb or release the

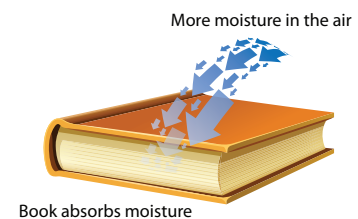
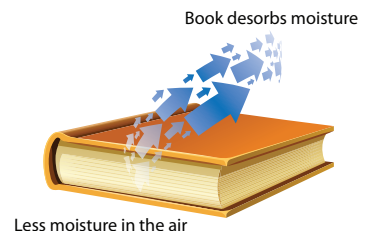

appropriate amount of moisture. Only if the new humidity conditions last long enough will the entire object reach complete moisture equilibrium with the environment. Attaining complete equilibrium with the environment is referred to as 100% equilibration. If an object has not had time to completely equilibrate to a new condition, it may only be 25% or 50% equilibrated.

To see how objects respond when they are freely exposed to humidity changes, researchers at IPI exposed a variety of materials without enclosures to two different humidity scenarios at a constant temperature 70°F:

- a onetime change from 20% to 50% RH, to see how fast the materials absorb moisture
- a onetime change from 50% to 20% RH, to see how fast the materials desorb moisture

The materials used included 1" magnetic tape, ¾" magnetic tape, a 35mm film roll, a 16mm film roll, a single book, a book in the middle of a group, a stack of papers, and a stack of mounted photographs.

- The fastest equilibration time was seen when the ¾" magnetic tape was exposed to drier conditions. It took less than half a day to release enough moisture to reach 50% equilibration.
- The longest equilibration time was seen when the stack of mounted photographs was exposed to drier conditions. It took 15 days to release enough moisture to reach 50% equilibration.

Because the rate of equilibration drastically slows down as it approaches 100%, we can't assume that 100% equilibration will be reached in double the time for 50% equilibration. However, we can use the time to 50% equilibration as a benchmark to gauge how slowly equilibration can occur.

**A sudden or short term fluctuation of relative humidity does not affect the moisture content of objects in the space immediately. In fact, if the increase is temporary, the bulk of the object may not "feel" the change at all.**

IPI's research showed that:

- A hardcover book alone on an open, wire shelf, with its surface exposed to the environment on all sides, took two days of sustained humidity conditions to reach just 50% equilibration.
- A hardcover book stacked between other books on a shelf will equilibrate to a 20% change in RH in about one month.



**CONCLUSION:** Periods of sustained high humidity in the summer and sustained low humidity in the winter are much more significant in terms of preservation than sudden or short term fluctuations in RH.

## CHAPTER 2: The Factors that Shape the Storage Environment

The storage environment is shaped by a series of interrelated circumstances. This nested relationship begins with the local climate, particularly the seasonal moisture and temperature profile. The next level of influence includes the building envelope, which provides the first level of protection between the climate and the collection. The passive or mechanical system designed to deal with the extremes and variations of the local climate comprises the third level. Other factors come into play as well, including the needs of the collection, the activities that take place in the space, and the operating patterns of the mechanical system.

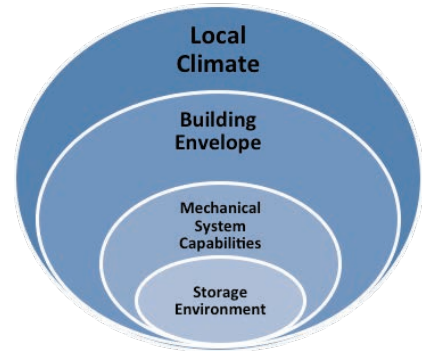

### 2A The Local Climate

The local outdoor climate is very important because it has a significant influence on what happens indoors. All the air inside the building came from the outside initially. The building's mechanical system, no matter how simple or how complex, was designed to deal with the outside air, particularly the extremes of heat and moisture. The climate situation that mechanical systems are designed to manage will vary depending on the regional climate patterns.

#### Climate Zones in the Continental United States

The United States can be divided into specific climate zones which vary in temperature, humidity, and dew point based on geographical differences such as elevation, latitude, and average rainfall.

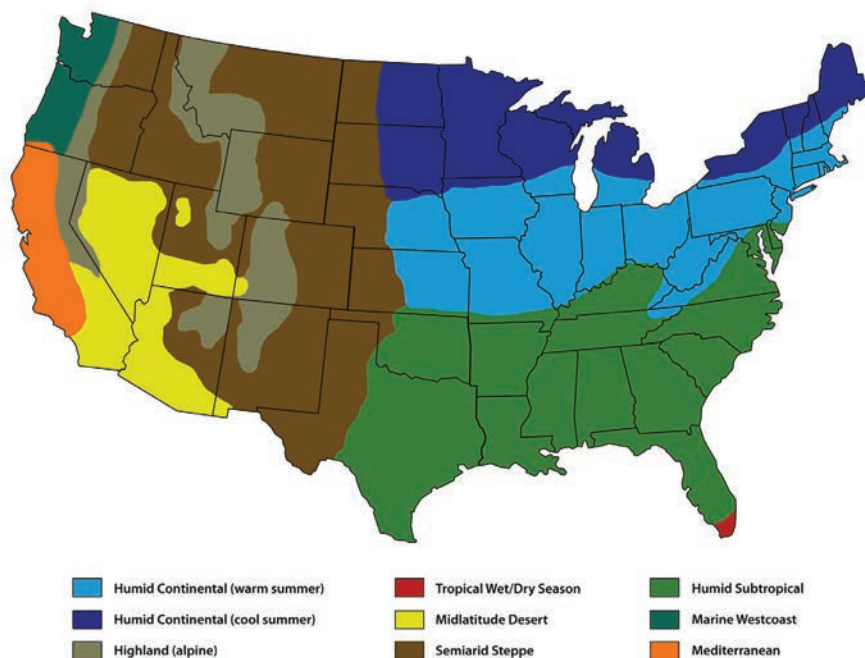

## Preservation Challenges in Various Climates

Regional climatic differences influence the environmental management requirements for collections preservation. The descriptions below provide an overview of the challenges presented by various climates in the United States:

### Continental Climate

WARM TO COOL SUMMERS AND COLD WINTERS

Mechanical systems should be designed to protect collections in storage from extremes in temperature and relative humidity year round. This requires the use of cooling and dehumidification in the summer to reduce temperature and humidity levels and the use of heat and humidification in the winter to increase temperatures and add moisture.

### Dry (Desert and Semiarid Steppe) Climate

VERY DRY, COLD AT NIGHT AND HOT DURING THE DAY, LITTLE RAIN

Mechanical systems should be designed to manage wide fluctuations in temperature. Good air filtration is required to protect collections from dust and soot. Collections should be protected from high levels of sunlight, which can increase the rate of deterioration in vulnerable materials. High humidity is rare. The system should add moisture during periods of low RH to avoid damage to collections from dryness.

### Subtropical Climate

WARM AND HUMID SUMMERS WITH MILD WINTERS

The sub-tropical climate is conducive to mold and mildew growth and biological decay. Exterior walls may be susceptible to condensation problems when warm humid air meets cold surfaces. Both adequate moisture barriers and good air circulation are important to protect collections from accelerated decay. Mechanical systems need the ability to increase temperatures and to dehumidify to reduce high RH levels

### Tropical, Warm and Humid Climate

HEAVY RAINFALL, HIGH HUMIDITY AND HIGH TEMPERATURES

The tropical climate is conducive to biological decay and insect growth. High RH increases the rate of deterioration due to moisture absorption—all organic materials are at risk. Moisture barriers, good air circulation, and the ability to dehumidify are very important.

Historically, regional climate influences the development of regional architectural styles. Thick adobe walls offer shelter from the sun and keep interiors cooler in hot, dry climates. Verandas, courtyards, porches and high ceilings provide protection from the sun, particularly in the south. Homes in tropical areas feature elevated floors, louvered grilles and shutters, and balconies to promote air circulation.

## Regional Outdoor Data

Outdoor data typically shows moderate daily fluctuations in temperature and quite significant daily fluctuations in relative humidity. Seasonal trends are actually more important—most places have a cold winter season and a warm summer, but this can vary by region.

The following graph shows a full year of temperature data from five regions in the United States—Las Vegas NV in the Southwest, Key West FL in the Southeast, New York NY in the Mid-Atlantic, Medford OR in the Northwest and Rock Springs WY, which is on the west end of the Midwest. The key above the graph identifies the colors that correspond to each city. Although temperatures rise in the summer in all regions, the difference between the cold winter temperatures and the hot summer temperatures is more significant in some areas than in others.

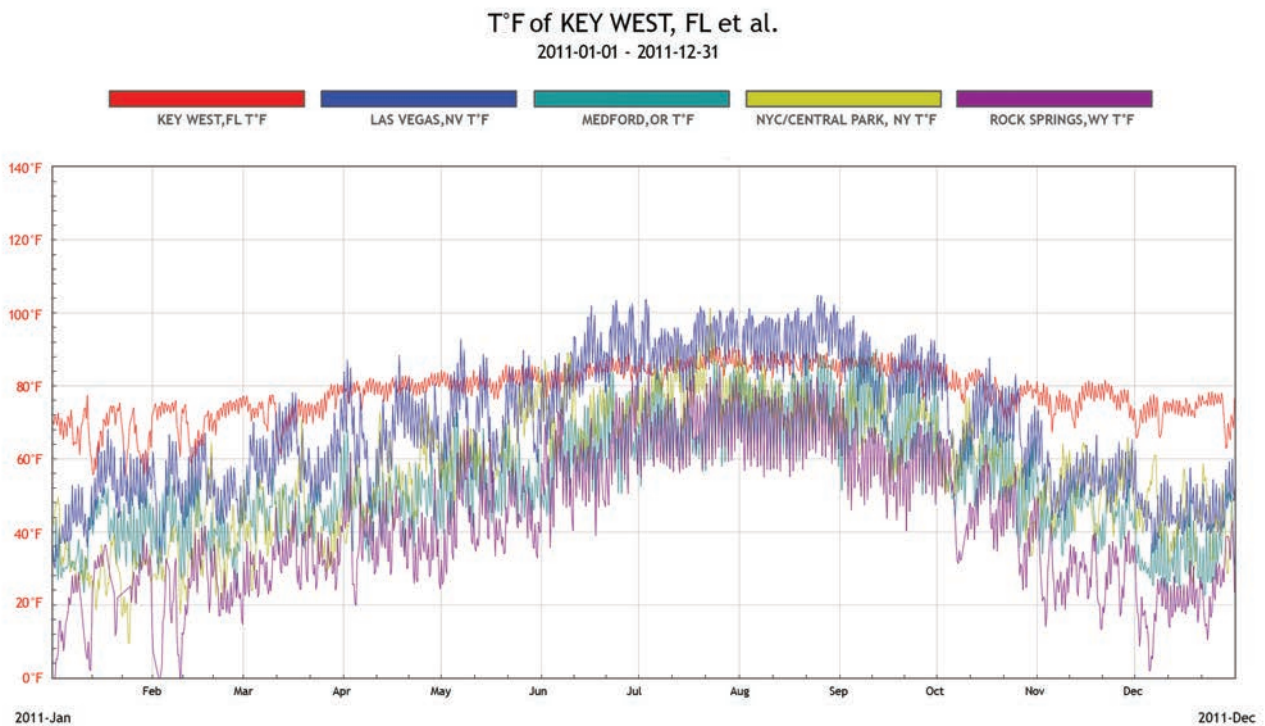

Relative humidity trends over the year will be a function of temperature and dew point. In many temperate areas the shape of the temperature and dew point graphs are similar, peaking in the summer when air is hot and holds lots of moisture. The opposite is true in winter when air is generally cool and dry. In tropical locations the dew points are high all year long, the temperatures are uniformly quite warm, and the RH line is flatter in shape over the year and consistently high.

The following graph shows a full year of relative humidity data from the same five locations. It shows both the extreme differences in outdoor RH between regional climates and the large daily variation of outdoor RH caused by daily variations in temperature.

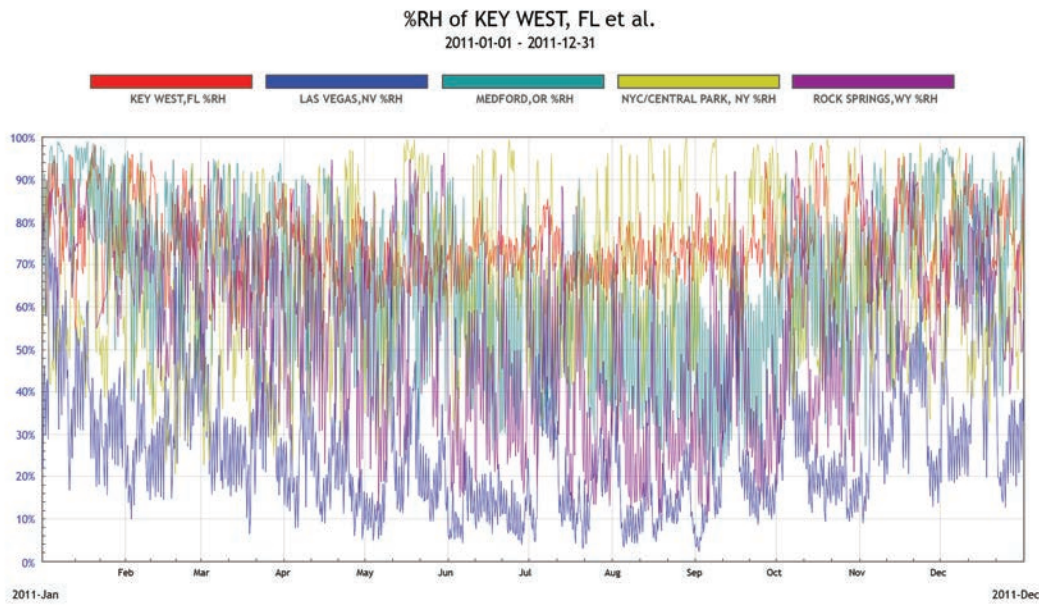

The final graph shows a full year of outdoor dew point data from the same five locations. It clearly shows the large variations in moisture content of outdoor air from different climatic regions. Remember that it is this moisture that the mechanical system has to manage, avoiding dangerously high or dangerously low levels of moisture in the environment.

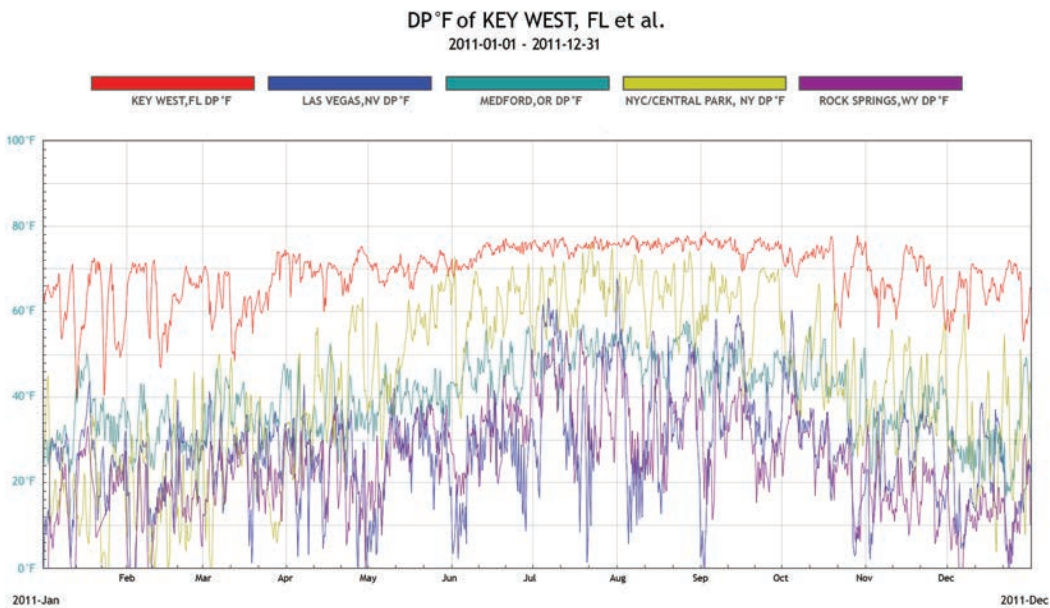



The table that follows provides an overview of the average temperature, relative humidity, and dew point temperature for each of the cities illustrated in the preceding graphs.

City	Start Date	End Date	Avg. Temp	Avg. RH	Avg. Dew Point
Key West, FL	1/1/11	12/31/11	78°F	75%	69°F
Medford, OR	1/1/11	12/31/11	53°F	66%	40°F
New York, NY	1/1/11	12/31/11	56°F	66%	43°F
Rock Springs, WY	1/1/11	12/31/11	43°F	55%	25°F
Las Vegas, NV	1/1/11	12/31/11	69°F	27%	28°F

A review of the environment in your locality is the best way to understand your building's mechanical system performance and begin to evaluate the preservation quality of the environment your collections are stored in. This is done by comparing graphs of local outdoor environmental data with data collected within the storage space during the same period. A comparison of the dew point temperature data is particularly informative (see Section 6C for more).

## 2B The Building Envelope

The building envelope provides the first level of protection against the outdoor environment. It includes all of the elements that mediate between the indoors and outdoors, including the roof, doors, walls, windows, chimneys, and other above-grade components. The building envelope also encompasses below-grade components such as basement walls, floors, crawl spaces and insulation. Among the environmental factors that the building envelope mediates are thermal gains and losses from conduction and solar radiation and moisture gains and losses of water vapor, liquid water and soil moisture.

### Building Classifications

Ernest Conrad of Landmark Facilities Group, Michael C. Henry of Watson & Henry Associates, Richard Kerschner, Chief Conservator at the Shelburne Museum in Vermont and others frequently refer to the following building classifications:

#### CLASS ONE BUILDINGS

Open structures (shelters, lean-tos)

#### CLASS TWO BUILDINGS

Sheathed post and beam structures, wood or metal-clad wood frame buildings (sheds, barns, cabins, mills)

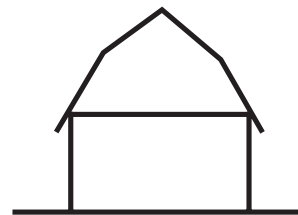

### CLASS THREE BUILDINGS

Wooden structures with framed and sided walls and single glazed windows or un-insulated masonry structures, with shallow crawl spaces or basements (standard historic house types)

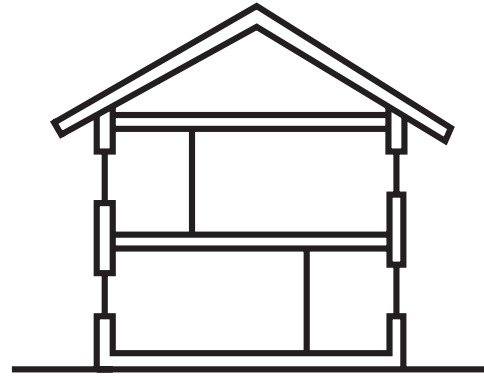

### CLASS FOUR BUILDINGS

Tightly constructed wooden structures or heavy masonry structures with composite plastered walls, single glazed or storm windows (typical high quality historic houses; residential, education, civic and religious buildings)

### CLASS FIVE BUILDINGS

Newly-built structures with metal or concrete frames, tight construction with insulated walls, vapor barriers and double glazed windows (museums, libraries, office buildings, storage and industrial buildings)

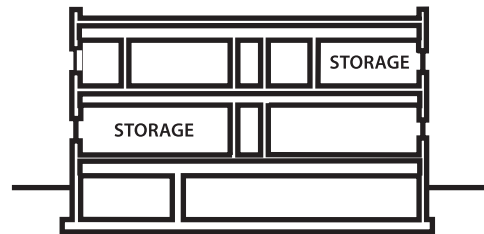

### CLASS SIX BUILDINGS

Rooms-within-a-room, double wall construction with insulated and sealed walls (storage vaults specially built to support precision environmental control)

## A Brief History of Heating and Ventilation

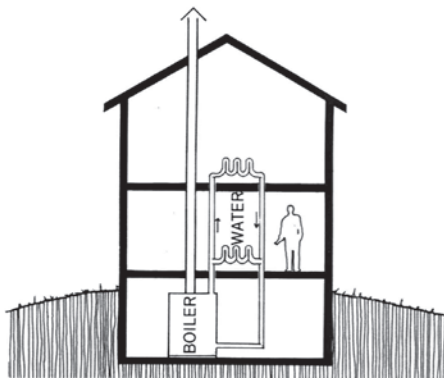

Peter Herzog, architect and energy efficiency expert with Herzog/Wheeler & Associates in St. Paul, Minnesota, provides an overview of the evolution of building design and climate control through the following illustrations and information:

One of the primary reasons why humans created buildings was to help keep out the elements—rain, snow, wind, and cold. Heat was provided by building a fire in the space where heat was desired – evolving from a fire pit, to a fireplace, and finally to a stove. All of these require bringing a fuel source into the space and providing a means of exit for smoke and other products of combustion. A

major step in the evolution of heating systems came with the invention of a method to locate the heat-producing fire somewhere remote from the space to be heated, and to provide heat to multiple spaces from a single remote fire. These systems consist of a boiler or furnace to contain the combustion and employ steam, hot water or heated air as a means of conveying the heat to the desired location. By the late 19th century, steam and hot-water radiators had replaced fireplaces and stoves as the source of heat in many spaces.

Windows, designed to let in light, also provided ventilation. Building design allowed for this ventilation by including double hung windows and transoms above doors. However, this only works if the building is no more than two rooms wide.

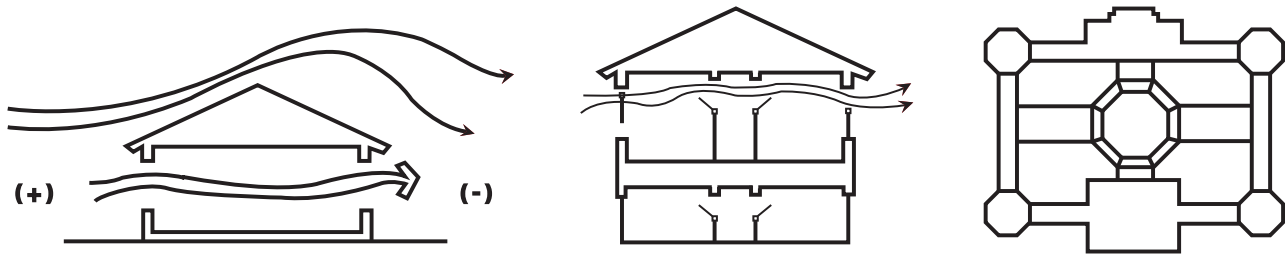

In the early stages of this evolution, large buildings included courtyards or were designed in T or H-shapes to accommodate the need for air flow through the space and provide access to daylight in every room. Eventually, use of electricity allowed for a constant source of ventilation with the incorporation of fans, designed to let outside air in and take inside air out.

Electricity provided a constant source of light, and facilitated control of heating, ventilation and air conditioning. Forced air heating systems with ducts and registers allowed the configuration of buildings to change. Central air conditioning was introduced in the 1920s and by mid-century forced air systems with combined heating and air conditioning using the same ductwork were available.

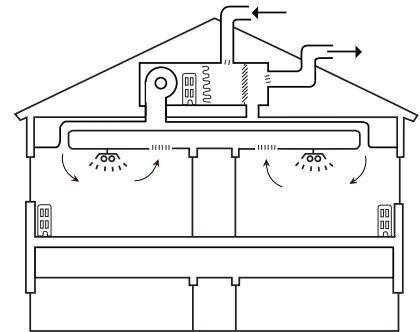

The development of high-rise buildings, heating and air conditioning systems and full service electric lighting exploded after WWII. Today's buildings are no longer dependent upon their perimeter for light and air, and they are sealed from the exterior and "breathe" through their climate control or HVAC (heating, ventilating, and air conditioning) systems. The outdoor climate still matters – all the air coming into the building comes from the outside, along with the heat, the cold, and the moisture level.

## 2C Mechanical Systems

Common mechanical systems and the challenges and opportunities they provide for managing the environment for preservation can be reviewed based on the building classification (described in 2B), as noted below:

### CLASS ONE BUILDINGS

Buildings generally have no mechanical system and have little or no potential for environmental improvement.

### CLASS TWO BUILDINGS

Buildings normally offer only ventilation (windows and doors) to reduce heat and moisture accumulation. There are usually no vapor barriers or insulation. There is minimal difference between the indoor and outdoor environment.

### CLASS THREE BUILDINGS

Buildings usually lack insulation or vapor barriers. These buildings tend to have mechanical systems designed to provide temperature control only (radiator heat for example) with no ability to control humidity. Periods of low RH can dry and crack historic surfaces. High RH can cause moisture to collect or migrate into walls, resulting in rotting wooden elements, rusting metal surfaces, efflorescence and salt deposits on masonry, mold outbreaks, and peeling paint.

### CLASS FOUR BUILDINGS

Buildings may have attic insulation but generally don't have vapor barriers. These buildings often have a ducted system of heating and cooling which may be capable of low-level heating and limited humidification in winter, cooling and re-heating for dehumidification in summer.

### CLASS FIVE BUILDINGS

Buildings have well-insulated walls and roofs, vapor barriers, and double-glazed windows. They can support complete HVAC systems with winter comfort heating and humidification, summer cooling and re-heating for dehumidification.

### CLASS SIX BUILDINGS

Buildings are well-insulated and sealed to support precision controlled heating, cooling, and humidity control systems.

## Basic Environmental Management

The forces that affect indoor climate are primarily related to the building envelope. In summer, interior spaces can be affected by heat conducted through exterior walls and roofs, by solar radiation through windows, and by the infiltration of outside air through openings in the building envelope. Similarly, in winter, conduction and infiltration can cause interior spaces to become cool.

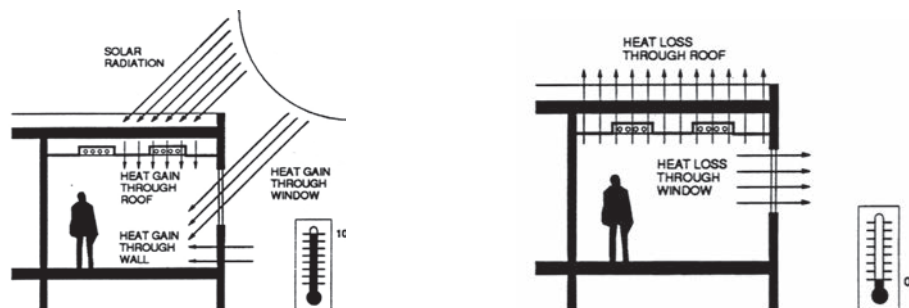

Simple modifications can be employed in buildings without sophisticated mechanical systems. You can limit solar gain by using shades and shutters and reduce heat gain and loss by adding insulation wherever possible. Portable climate control equipment including humidifiers, dehumidifiers, heaters, and air conditioners can be used to manage extremes of relative humidity and temperature. It is important to eliminate sources of moisture by repairing leaks, replacing damaged gutters and downspouts, and correcting drainage problems.

## Mechanical Systems in Class Three and Four Buildings

Buildings with heating only, supplied by a hot water or a steam boiler, typically have a single thermostat that tells the boiler when to operate. Often the temperature in rooms other than the one where the thermostat is located will be indirectly controlled. Some systems however do provide the ability to control the temperature in each individual room by thermostatically controlling the flow of hot water or steam to individual radiators or convectors. These systems have no ability to control moisture. Portable humidifiers or dehumidifiers can be used to control relative humidity in individual spaces.

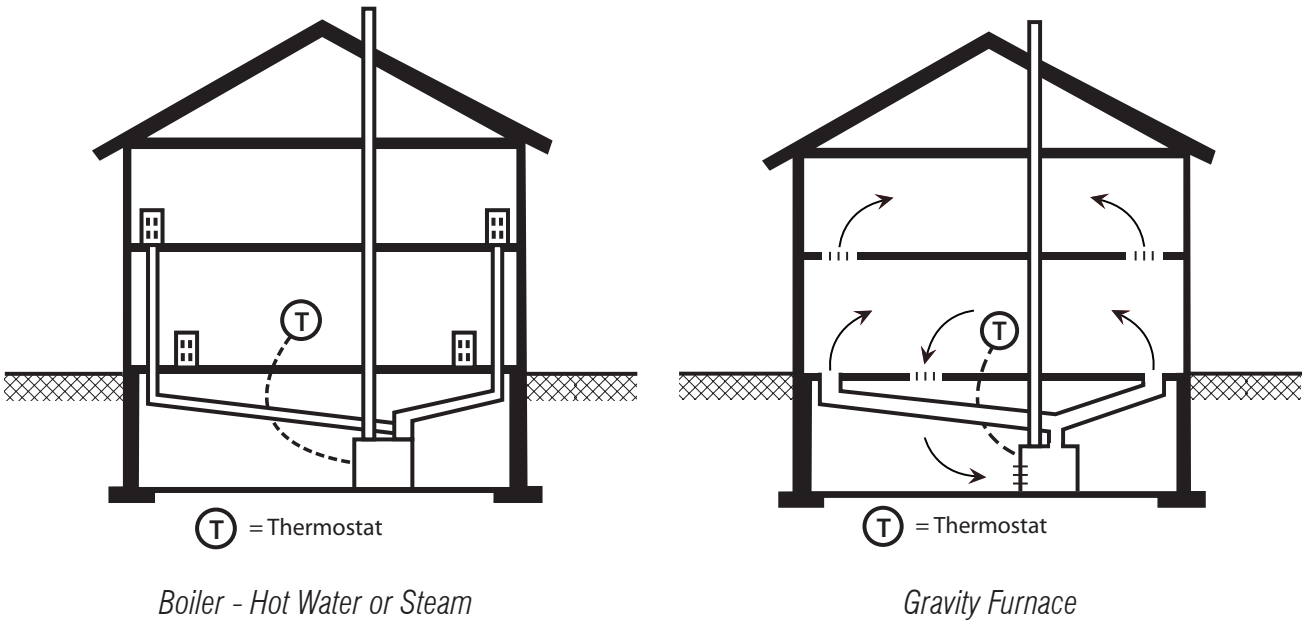

Buildings with forced air furnaces supply heat by ducting a stream of hot air to each space to be heated. The furnace typically operates to satisfy a thermostat located in one space. The temperature in all other heated spaces is indirectly controlled by manipulating manual balancing dampers to adjust the portion of heated air that enters each space. A humidifier can be installed at the furnace and controlled by a humidity sensor that measures the relative humidity of the air returning to the furnace from the spaces. There is no ability to control the relative humidity of individual spaces.

Cooling capacity is commonly added to these systems to deliver cooled and dehumidified air to the spaces through the same ducts. It consists of an evaporator (cooling) coil in the air stream to absorb the heat, and a condenser/fan unit located at the exterior to reject the heat outside.

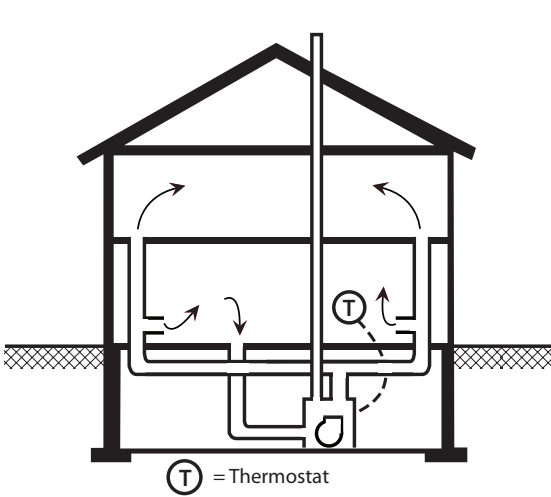

*Forced Air Furnace with Electric Fan*

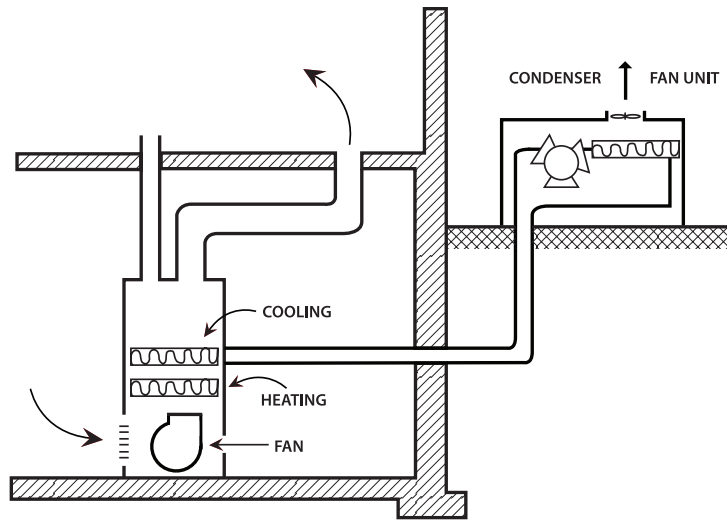

*Forced Air Furnace with Cooling—Fuel plus Electricity for Fan, Compressor & Condenser*

## Mechanical Systems in Class Five and Six Buildings

The forces that affect indoor climates in Class Five and Class Six buildings include the same heat gain and heat loss through the building envelope as previously explained, but they also gain heat from internal sources. Since these buildings do not depend on exterior walls for light and ventilation, many spaces have little or no exposure to the building envelope and may be partially or entirely surrounded by tempered spaces. In these cases, spaces are unaffected by outdoor weather, but must deal with internal forces such as people, lights, and equipment that all produce heat. For these buildings the need to accommodate fluctuations in outdoor conditions is entirely driven by the amount of outdoor air purposely brought into the spaces.

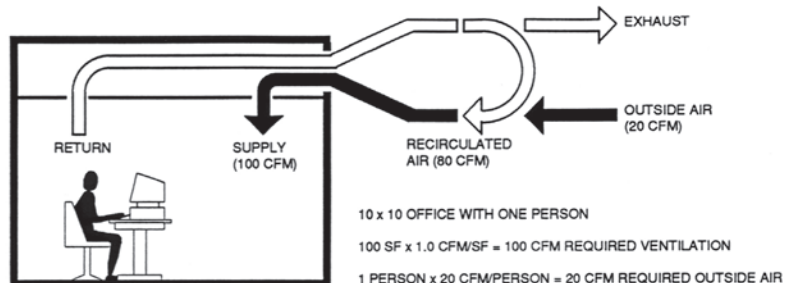
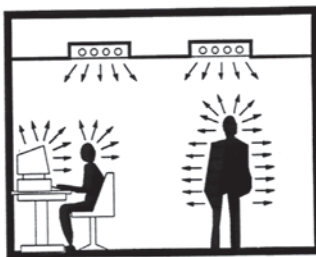
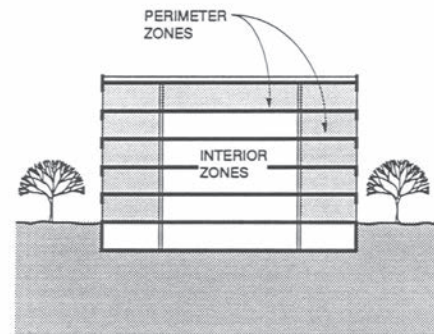

Storage spaces in Class Five and Class Six buildings are generally isolated from their surroundings, and all of their climate control needs must be met by their heating, ventilation and air conditioning (HVAC) system. These systems are designed to constantly move a stream of air through the space as a means of conveying heat and/or humidity into or out of the space as required. A fraction of this air stream typically consists of fresh outdoor air and the remainder is recirculated.

## The Loop—Components of a Typical Air Handling Unit (AHU)

Climate control systems can best be understood if they are conceived of as a moving loop of air that enters the space, passes through it, leaves the space, returns to the place where the conditions of that air are appropriately altered (air handling unit) and returned again to the space (see diagram below). It is along this loop of moving air that temperature can be raised or lowered, humidity can be raised or lowered, filtration can occur, and outside air can be added or removed.

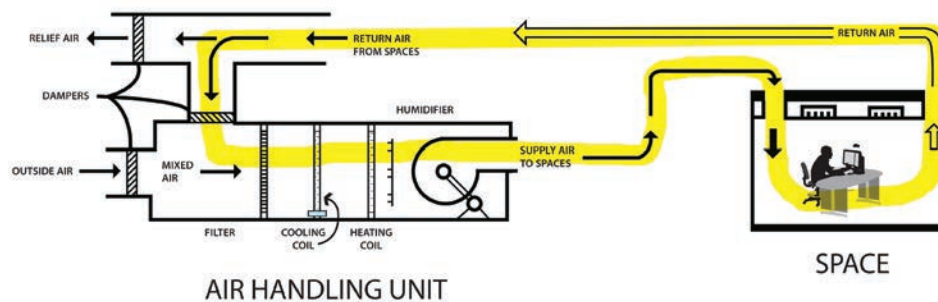

There are several typical components of an AHU, and each can alter the conditions of the moving loop of air, and ultimately the environment in the space. These components are described below.

### SUPPLY AIR FAN

The energy to move the loop of air is supplied by a fan powered by an electrical motor. It pushes the air out to the spaces through the supply air ducts and draws it back through the return air path. In some systems a second fan is employed to assist with pulling the return air back to the AHU. Most fans serving collections spaces operate at a constant speed. However, some are equipped with variable speed drives that allow you to adjust the speed at which the volume of air in a space is exchanged.

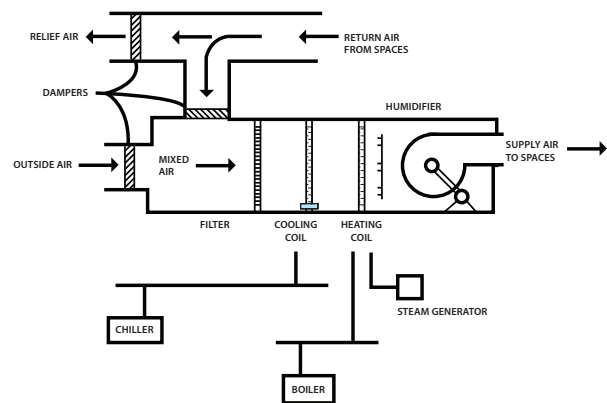

*Air Handling Unit with Peripheral Elements*

### HUMIDIFICATION

If a sensor, usually in the return air stream, detects that the space relative humidity is too low, the humidifier injects water vapor into the supply air stream. This water vapor is typically in the form of steam that is produced by a small steam generator (peripheral to the AHU) heated by steam, electricity, or gas.

## HEATING

Heating is provided to spaces by passing the stream of air over a warm heating coil and conveying that air to the space. Heating coils are controlled by a thermostat. Hot water or steam produced by the boiler (peripheral to the AHU system) allows the selected temperature to be achieved in air passing through the heating coil. On occasion heat may be introduced to a space directly using convectors or radiators.

## COOLING AND DEHUMIDIFYING

If a sensor in the space detects that the space is too warm, the stream of air is passed through a cold coil before being supplied to the space. The coil is cooled by a flow of cold water supplied by a chiller (peripheral to the AHU system) or by the evaporation of a refrigerant provided by a remote compressor/condenser unit (known as DX cooling). If the temperature of the cooling coil is below the dew point temperature of the air, moisture will condense on the coil, thereby dehumidifying the air. In cases where the desired space dew point temperature is quite low (e.g. 45°F) at least some of the air must be cooled to 45°F. Because 45°F is colder than the desired space temperature, this sub-cooled air must be reheated. Such arrangements are called sub-cool/reheat systems.

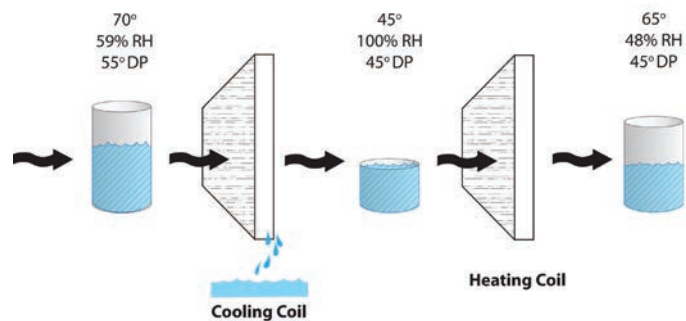

*Dehumidification by Sub-cooling and Reheating*

Some buildings have humidistatically controlled systems, which are designed to maintain a stable RH by manipulating and varying the temperature. A humidistat sensor adjusts the temperature up if the RH rises above a set point, and maintains it until the RH drops back. If interior RH is lower than exterior RH, dampers are opened by sensors and the air is circulated through the building. If exterior RH is too high, the dampers remain closed.

## AIR FILTRATION

Air filtration is provided by passing all air delivered to spaces through one or more filters to remove particulates. Often additional filters are added to remove gaseous components in the air. In some systems the outside air is separately filtered as it enters the system.

## MIXED AIR CONTROL

As the air from the spaces returns to the AHU a portion of that air is ducted outside (through the relief air damper) to make room for the introduction of fresh air through the outside air damper. Systems are typically designed to constantly introduce 10% to 15% outside air. This outside air is blended with the bulk of the return air in the mixed air chamber.



In some systems there is no process for relief air at the AHU. Instead, a volume of air equivalent to the outside air is allowed to exfiltrate from the spaces in order to keep them positively pressurized and thus avoid the infiltration of air from surrounding spaces.

## SYSTEM CONFIGURATION

Buildings often have multiple HVAC systems and these systems commonly serve multiple spaces. It is important to document each storage area's HVAC system and all of the spaces served by it. Some systems have devices that can alter the condition of the air as it enters individual spaces. One example is a thermostatically controlled damper that can vary the volume of air entering the space – a variable air volume (or VAV) box. Heating coils are another example. Some systems have both variable volume and heating coils.

### ***LIMITING THE AMOUNT OF OUTSIDE AIR CAN SAVE ENERGY!***

*It should be noted that, in Class Five and Class Six buildings, the need to humidify and dehumidify is directly related to the quantity of outside air admitted into the system. This is because the moisture content of the outside air (and therefore its dew point temperature) is almost always higher or lower than the desired storage space air moisture content (and dew point temperature). Read more in Section 9C.*

## 2D Energy Use in the Storage Environment

Collection storage areas are usually maintained at more stringent temperature and humidity conditions than other spaces and as a result these spaces consume more energy than other areas. As a result facility managers and administrators are looking to collection care staff to consider energy-saving alterations to the operation of HVAC systems serving storage areas. The primary energy-consuming elements of a typical forced air HVAC system include the following:

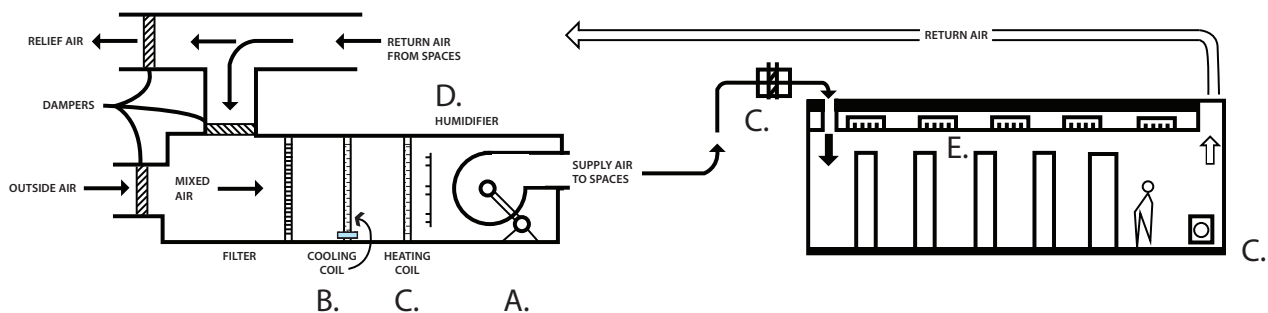

A. Air Handling Fans B. Cooling Coil C. Heating Coil D. Humidifier E. Lighting

## Air Handling Fans (A)

An air handling fan powered by an electrical motor provides the force necessary to move the air stream around its loop path from the AHU to the spaces served, back to the AHU and through various filters and coils. Some units have two fans, one to supply the air as shown above, and a second one to assist in pulling the return air back to the AHU. Most collection area AHU fans operate continuously and most run at a constant speed. Some are equipped with variable speed drives, and therefore it is possible to operate them at less than full speed based on a schedule or some sensor input. The factors that determine how much energy an existing fan motor will use are:

- Motor size (watts consumed at full load)
- Speed of operation
- Hours of operation

## Cooling Coil (B)

Cooling coils absorb heat energy that is conveyed from the coil to chilling equipment to reject that heat to the air outside. The warmer and moister the outside air is, the more electrical energy the cooling system requires to reject heat into it. While there are a number of factors within the chilling system that affect its efficiency and energy consumption, the key factors that affect the amount of cooling work (and therefore the cooling energy consumption) at the cooling coil are:

- The temperature and RH of the air returning to the AHU (heat gains at spaces served)
- The temperature and RH of the outside air (dew point temperature)
- The amount of outside air
- The total amount of air cooled / dehumidified
- The temperature and RH of the air after the cooling coil (related to space temperature and RH set points)
- Annual hours of operation

## Heating Coil (C)

When heat is required, the stream of air passing over the heating coil picks up heat. Air passing over an otherwise ambient temperature heating coil can be heated by introducing some source of heat (steam, hot water, electrical resistance) into the coil. The steam or water is heated by a boiler located somewhere remote from the AHU. The ultimate source of this heat is the combustion of some fuel (natural gas, fuel oil, coal) or electrical resistance heat. Like chilling systems, boiler systems have a number of factors that affect their efficiency and energy consumption.

The key factors that affect how much heating energy is consumed at the heating coil are:

- The temperature of the air returning to the AHU (heat losses at the spaces served)
- The temperature of the outside air
- The amount of outside air
- The total amount of air heated
- The temperature of the air after the heating coil
- Annual hours of operation

## Humidifier (D)

Whenever the relative humidity of the air returning from the storage spaces is lower than the set point, the humidifier injects water vapor into the air system. This usually takes place just before the air leaves the AHU. Some humidifiers inject moisture into the air stream in the form of steam originating from a central steam system, or from a small dedicated steam boiler heated by gas or electricity. Other humidifiers atomize water using ultrasonic waves, or by forcing the water through small nozzles at high pressure. The energy required to atomize the water varies considerably, with boiler-heated steam being the most energy-consuming, and the ultrasonic vaporization among the least energy intensive systems.

It should be noted that humidification typically represents less than 7% of the annual energy consumed by a storage space HVAC system, even in northern climates where winter-month humidification needs are the highest. The factors that determine humidifier energy consumption are:

- The absolute humidity (dew point temperature) of the outside air
- The amount of outside air
- The space temperature and RH set point (and corresponding absolute humidity)
- Hours of operation

## Lighting (E)

Lighting can be a significant contributor to total annual energy consumption. As the illustration on p.26 shows, a storage area's climate control system can be conceived of as a loop of moving air that connects a number of locations where energy is consumed. Lighting can be a significant contributor to total annual energy consumption depending upon the total watts of installed lighting and the hours of operation. The energy consumed to produce light also produces an equivalent wattage of heat that is carried by the return air stream to the AHU, where it typically must be removed by the cooling coil.

## Summary of Energy Consumption

While the annual cost of energy to provide a storage area's climate control will vary widely depending

upon system configuration, current utility rates and region of the country, the following allocation for a typical system in a “Continental Climate” zone (p. 17) will provide some perspective on the contribution each component makes to the total annual cost of energy.

Component	% of Annual Energy Cost
A. Air handling fans	19%
B. Cooling coil	30%
C. Heating coil	40%
D. Humidifier	5%
E. Lighting	6%

In existing collection storage mechanical systems, factors such as weather, the building envelope and the configuration of the AHU, are relatively fixed and not capable of manipulation in the interest of energy use reduction. However, there are several factors subject to manipulation that can significantly affect energy consumption. These include temperature and RH set points, quantity of outside air, total air flow, and hours of operations. Chapter 9 discusses energy saving opportunities in more detail.

## 2E Institutional Stakeholders

Section one of this guidebook is focused on what you need to know to define an optimal and sustainable preservation environment. We’ve pointed out that you need good background information about the collections in your institution and how they react to the environment, you need to understand all the elements that determine the climate in the storage area, and you need to know what opportunities for energy savings should be considered. The next step is to identify who you need to involve to gather this information and negotiate the optimal environment? Who are the institutional stakeholders?

### Create an Environmental Management Team

In order to make changes to the current environment that truly have an impact, it’s important to include people who affect and create the storage environment in the process. We recommend a cross-functional team with at least one permanent representative from collection care (conservation, collection management, curatorial, preservation), and one or more from facilities (engineers, building operators, facility managers). You may also need someone in an administrative capacity on the team. Often large institutions or college campuses have someone assigned to sustainability and energy savings, and this person should be asked to join the team.



These individuals should be considered representatives of their co-workers and areas of responsibility, with an obligation to present their concerns and report back on team discussions and decisions.

The work of the Environmental Management Team should be considered an ongoing activity, ideally with someone assigned as a champion of the task and with long-term administrative support. Representatives from Facilities bring their knowledge of building operations, and mechanical system functions and capabilities. Collections representatives have generally monitored the environment and have collected data to review, and know where the most vulnerable materials are stored. The Administrative team member should be someone who can affect activities within the storage area, can enforce changes in routines or functions as needed, and can get funding for equipment if needed.

Collections staff are used to a management approach that includes asking for specific set points and parameters, then watching for excursions outside of these limits. Facilities staff are used to being told what environment is needed, and then reacting to emergencies and comfort complaints. The Environmental Management Team should develop a new approach to managing the environment which will be a collaboration, a sharing of information, and a negotiation. The goal is to define an optimal and sustainable preservation environment that is:

- Best for the collections in your institution
- Achievable given your regional climate, your building and its mechanical system
- Acceptable to the occupants of the space
- The least energy-consuming

Managing the environment has an effect on the fiscal health and everyday working life of the institution. The capital expense, increasing energy costs, and other operating expenses associated with providing heating, cooling and ventilation have a significant impact on institutional budgets. At the same time, the value of institutional collections cannot be overstated and the responsibility to provide adequate stewardship is primary. As we have noted, the storage environment plays a significant role in the ability to preserve collection material over the long term. An effective solution to managing the environment to achieve both collection preservation and energy efficiency can only be achieved if environmental management is a team effort. IPI's experience has shown that most institutions can improve the preservation of collections and contain energy costs when the right people work together to understand, evaluate, and improve the environment in their institution.

*A growing body of research suggests that institutions can more easily develop effective and affordable preservation measures, particularly those that manage the environment surrounding collections, by undertaking collaborative and interdisciplinary planning. We therefore encourage interdisciplinary planning that analyzes collections and their current conditions and risks, the characteristics of the building that houses the collections, energy usage and environmental impact, and local climatic conditions.*

*National Endowment for the Humanities, Sustaining Cultural Heritage Collections FAQs, [http://www.neh.gov/grants/guidelines/SCHC\\_faqs.html](http://www.neh.gov/grants/guidelines/SCHC_faqs.html)*

# SECTION 2: WHAT YOU NEED TO DO

ACHIEVE THE LEAST RISK TO COLLECTIONS AND THE BEST ENERGY SAVINGS POSSIBLE

## Section Two includes four chapters:

- Chapter 3: Document the Current Storage Environment
- Chapter 4: Document Each Storage Facility's Mechanical System
- Chapter 5: Understand the Role of Dew Point
- Chapter 6: Analyze Collected Data

These chapters introduce the primary steps involved in achieving an optimal and sustainable preservation environment. Armed with an understanding of the environment, its effect on material decay, and the factors that shape the storage environment, you are ready to dig deeper into the reality of your own situation.

Section Three – Institute Sustainable Preservation Practices – will cover the activities required to maintain an optimal and sustainable preservation environment, including the development of an Environmental Management Team and suggestions for investigating opportunities for energy savings in your institution.

## 3

### CHAPTER 3: Document the Current Storage Environment

Environmental monitoring is undertaken in order to understand how the storage environment is affecting the preservation of collections. Historically, this task resulted in handwritten logs of temperature and RH or weekly charts made by hygrothermographs. How much could this data tell us about the preservation quality of the space and the long term effect on collections? With a focus on “flat line” temperature and “ideal” RH ranges, the short-term data available could identify any deviations from targets and set points. Unfortunately, this short-term perspective worked against the consideration of more significant trends such as seasonal variation and equilibration rates.

Today, we have the ability to collect data electronically and to use computer programs to do extensive calculations on collected data. Computers can quickly condense a whole year of data onto one graph and provide a long-term, statistic based evaluation of the preservation quality of the storage space.

## 3A Collect Appropriate Data

Regular monitoring of environmental conditions will provide you with accurate statistical information, which should form the basis of both long and short term plans for collection care and preservation. It will enable you to document the actual environment in the storage area, and to illustrate how well the HVAC system is performing. Informed data analysis will allow you to head off potential preservation problems and see clearly how environmental conditions are impacting the life of the collection. Reliable data can be used to develop strategies to improve the storage environment and identify whether those strategies are actually working.



### Determine Who Will Monitor the Storage Environment

IPI's experience shows that environmental management usually works best when the collections care staff (conservators, curators, archivists, preservation professionals) does its own independent monitoring of the environment in collection storage and display spaces. Collections care staff are responsible for determining whether the collections are well served by the environment they exist in. To fulfill that basic professional responsibility, they need temperature and relative humidity data from monitored spaces that reflect the conditions experienced by the collections (in some instances even inside objects or showcases), rather than just in ducts and on walls where building control sensors are placed. This data should be continuous, accurate, and in a form that allows for convenient organization and interpretation. When weighed against the importance of the environmental management task and the high cost of creating special climates, the time and expense of deploying dataloggers for use by preservation staff in fulfilling their basic professional responsibilities is small. Having 'their own' data is essential if collections care staff are to engage constructively with facilities staff in the effort to improve environments and manage risks to collections that arise from facility management and sustainability activities.

### Building Management Systems

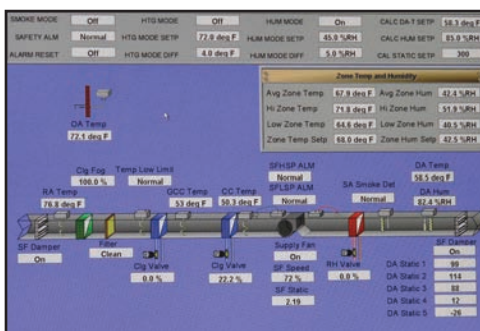

In some cases, data from BMS or EMS (Building Management Systems or Energy Management Systems) can also be used with moderate success. Modern building management systems are computerized and include centralized controls for mechanical systems and other devices used in facilities management. BMS sensors are placed to allow Facilities to monitor for control of specific equipment, not for long-term analysis of the storage environment. These systems may offer the capacity to 'trend' (store and graph data from control sensors in spaces) and export that data to other software for further analysis. However, in many real-world situations it becomes too time-consuming and cumbersome for facilities staff to perform comprehensive monitoring using the BMS. The BMS is a tool for control and is not designed for extensive data analysis. In addition, BMS system designs are secure and proprietary, and they can be quite complex to program.

## 3B Environmental Monitoring Tools

The choice of monitoring hardware depends on your institutions monitoring goals and how you intend to use collected data. Monitoring devices vary in size, accuracy, data capacity, ease of use, battery life, and of course, cost. There are spot measuring devices as well as continuous recording devices. Some devices have displays and some do not. Monitors may be connected to computers via radio signals or network cables and can therefore collect data in real time. Standalone dataloggers store data internally until it can be retrieved and uploaded to a computer for graphing and analysis. This data transfer can be done with a USB cable or portable memory card. Commonly used environmental monitoring tools are described below.

### Psychrometers

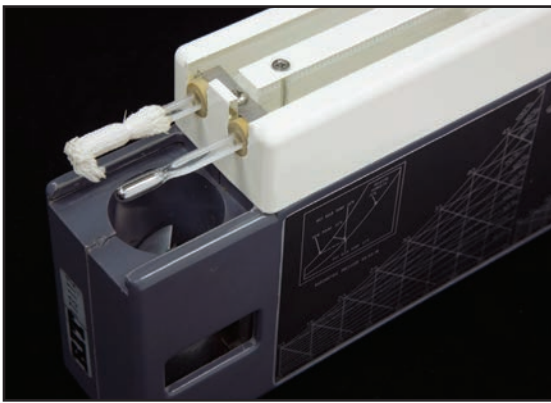

Psychrometers are used to make daily readings, spot recordings, and to calibrate dial hygrometers and hygrothermographs. Psychrometers give you a relative humidity reading by comparing the temperature between a “dry bulb” and a “wet bulb.” The dry bulb is a mercury thermometer. The wet bulb is an identical thermometer covered with a wetted cotton wick. The cooling effect of evaporating water causes the wet bulb to read lower than the dry bulb. The drier the air, the faster the water evaporates and the lower the reading. There are two types of psychrometers—sling and aspirating. The sling

psychrometer has to be whirled around in the air for one minute and the results recorded immediately. The process should be repeated until you get the same readings twice in a row. The aspirating psychrometer uses a battery powered fan to blow air over the bulb at a set speed. According to ISO technical report 18931, the accuracy of wet-bulb/dry-bulb thermometers is  $\pm 5\%$  if all the variables are managed correctly. The thermometers that measure temperature have good long-term stability, so the problems with psychrometers usually arise from operator error or problems with the cotton wick.

### Hygrometers

Both dial and electronic hygrometers measure relative humidity. Dial hygrometers have a hygroscopic material, usually paper, attached to a hand on the dial. As the material absorbs or gives off moisture it expands and contracts, causing the hand to move across the dial. These instruments are inaccurate below 40% RH or above 80% RH and are difficult to calibrate. Digital versions have built-in temperature monitors. They are often calibrated with saturated salt solutions provided by the manufacturer.





## Hygrothermographs

Hygrothermographs provide a continuous record of temperature and relative humidity over a set period of time. These units include a temperature-sensitive element, usually a bimetal strip, and a hygroscopic element, usually a human hair bundle or a polymer membrane. A spring or battery operated drive rotates a paper chart which has been wrapped around a cylindrical drum. Recording pens attached to linkage arms rest on the revolving chart, moving up and down as the temperature and humidity sensitive elements react to changes in the environment.



When properly calibrated, hygrothermographs are accurate within  $\pm 3\%$  to  $5\%$ . They are most accurate within the 30% to 60% RH range and require frequent calibration—every few months ideally. Charts must be removed at the end of each recording cycle and pens require frequent maintenance.

Data can be assessed on a short-term basis by looking at the hygrothermograph chart. It is labor intensive, but the data can be typed into a data management program in order to see long term trends.

## Electronic Dataloggers

Electronic dataloggers measure temperature and relative humidity continuously and store the data for later graphing and analysis. The most common electronic humidity sensors use technology based on electrical resistance or electrical capacitance. When the relative humidity of the environment changes the sensor registers the change. Data collected by these devices is more comprehensive and more accurately reflects the actual environment experienced by collections.

There are many electronic dataloggers on the market that measure temperature and relative humidity data and make it available as graphs for analysis. The main types are standalone battery-operated units, and units that are hard-wired to an Ethernet or radio frequency units that include transmitters and a base station. The standalone units are the most popular and practical in most institutions. Individual units can range in cost from \$65 to \$800 (plus ancillary costs), depending on a range of variables including operating range, accuracy, data retrieval method, memory, battery life, etc. Design specifications and calibration standards vary greatly.



The accuracy of the most common devices can be as refined as  $\pm 2\%$  RH or as high as  $\pm 5\%$  RH depending on the accuracy of its calibration. The stability of electronic sensors also varies greatly. Under benign environmental conditions they can be very stable, but can drift over time, causing their readings to fall outside of their original accuracy range. The tendency to drift can increase if the sensor is exposed to extreme levels of temperature or humidity for prolonged periods of time. To ensure the most accurate readings, follow the recalibration schedule recommended by the manufacturer.

Electronic dataloggers require an associated software program that allows you to produce data graphs and tables. The software may be included or available for an additional charge. The features and capabilities of the programs vary a great deal as well. Some only produce data graphs, others allow you to manipulate data in a number of ways to generate reports, analyze trends, or extract information useful for collection preservation or HVAC management. When investing in environmental monitoring tools it is important to consider the initial cost of both hardware and software, as well as the time and effort required to upload and retrieve data, and to organize and analyze the data once you have it.

IPI strongly recommends managing environments using data in electronic form. Computers are absolutely vital tools for organizing, analyzing and reporting on environmental conditions. Non-computerized data gathering tools such as dial hygrometers and hygrothermographs are unsatisfactory because they do not allow for overviews of long-term trends or easy statistical analysis, and they preclude any use of more modern computational approaches such as IPI's Preservation Metrics™ (see Section 6B). Electronic dataloggers and other sensors connected directly to computer systems are usually more accurate, more effective, and less time-consuming to use than the other alternatives.

#### **Full Disclosure:**

*IPI developed an electronic datalogger based on our preservation research specifically for use by cultural institutions. IPI also has sophisticated collection management software. You can read more about IPI's Environmental Monitoring Products in Section 4 of this guidebook.*

### 3C Determine Where to Locate Environmental Monitors

We are often asked how many monitors are needed and where they should be placed. It is not as simple as saying use one logger per room or that one logger will cover so many cubic feet of storage space. Other factors should be considered depending on your goals for data collection and analysis. You may want to gather data from:

- Storage locations that hold the most important or valuable collections
- Storage locations that house the most vulnerable collections
- Storage areas that have different environments from others because they are served by different HVAC equipment
- An area where the HVAC system does not seem to be working properly
- Storage locations that have had environmental problems in the past—you may need data to justify the need for improvements

In a historic house consider monitoring north and south facing rooms which may receive differing amounts of heat from the sun. Basement storage locations may be effected by high humidity levels from open drains or soil moisture that produce higher dew points than above-grade spaces in the same building.

Place loggers on a shelf or near the cabinets where collections are stored. You may want to place

loggers midway between the floor and top shelf or ceiling, unless you have very tall bays of shelving and stratification is a concern. Avoid placing loggers near outside doors, air vents, radiators, cold walls, fans, and other sources of heated, cooled, dehumidified or humidified air.

It is important to measure temperature and humidity routinely, although in most cases it isn't necessary to download the data daily or even weekly – every few months is usually fine. It is important however to gather data from each location for at least one year so that the data you analyze covers the change of seasons (both heating and cooling seasons). Assign each monitor to a single collection area and leave it in place for a full year. Data collected over a short period of time has limited value for analysis.

### 3D Additional Considerations when Selecting Environmental Monitoring Devices

Desirable characteristics in an environmental monitoring device include simplicity of use, accuracy, overall expense, and the ease of data transfer to the computer where interpretation and graphing of the data will take place. The overall expense factor includes the cost of associated software, the cost and frequency of recalibration, and the time needed to set up, deploy, and periodically collect data from the loggers.

In June 2008, IPI developed a datalogger comparison table, which is available for review at <https://www.imagepermanenceinstitute.org/environmental/datalogger-comparison>. In 2011, conservator Rachael Perkins Arenstein researched the most commonly used data management tools and produced a document comparing dataloggers for museum monitoring for the National Park Service which is available at <http://www.nps.gov/museum/publications/conservoogram/03-03.pdf>.

Finally, consider how you will use and interpret the data you collect. Too often people focus on the price of the monitoring hardware and assume that once they have environmental data, its meaning will magically become clear. The reality is that making sense of data and putting it to practical use has always been the most difficult part of monitoring. See Chapter 6, Analyze Collected Data for more information on getting useful information from the data you have collected.

## CHAPTER 4: Document Each Storage Facility's Mechanical System

To achieve an optimal and sustainable storage environment it is very important to develop a clear understanding of the HVAC equipment that serves your storage areas. Work with facilities staff to create floor plans identifying the AHU that serves each storage area and an associated list of the areas served by each AHU. It is also instructive to prepare schematic diagrams which follow the air stream loop from the point it leaves the storage space by passing through the return air grills, moves along the return air path to the AHU, and then returns through the supply air ducts to re-enter the storage space via the supply air grills.



## 4A Create Floor Plans Indicating Collection Areas and HVAC Zones

We suggest that collection and facilities staff work together to create the mechanical system documentation described in this section. Start with either a basic floor plan of your institution, or a more detailed architectural drawing of each floor that contains storage or exhibition areas. The areas served by each AHU can be determined by studying the duct paths shown on the systems mechanical plans, but to do so requires some experience with reading this type of document. Facilities staff usually know most of the areas served by each AHU and can help determine any unknowns by tracing ducts and/or studying mechanical plans.

Indicate each HVAC zone on a copy of your floor plans as illustrated in the examples below. This exercise often reveals that some non-storage spaces are also served by the storage area AHU. This is important because adjusting the conditions in one area will effect all areas served by the system. You may want to attach a list of the locations served by the AHU to the documentation you prepare.

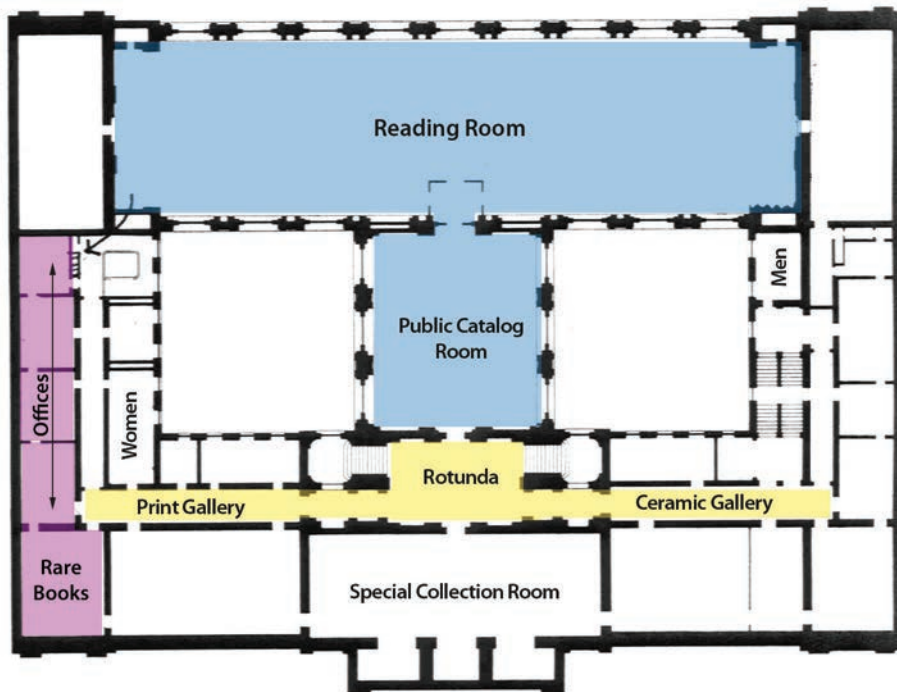

*Basic floor plan with colors indicating spaces served by separate AHUs*

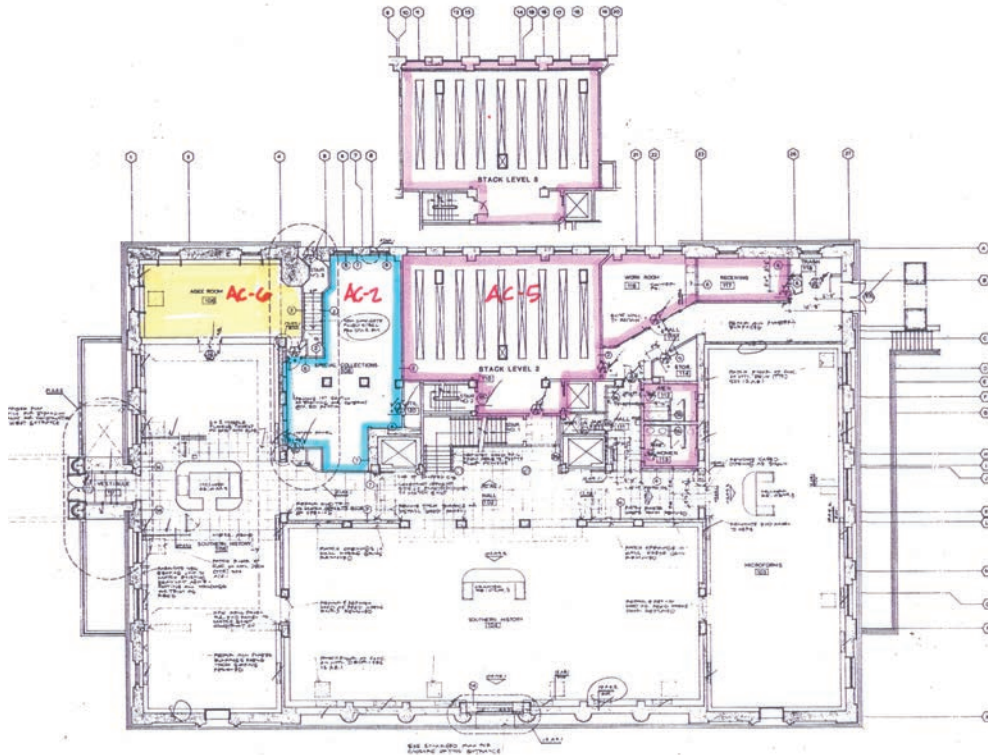

*Architectural floor plan indicating spaces served by three separate AHUs*

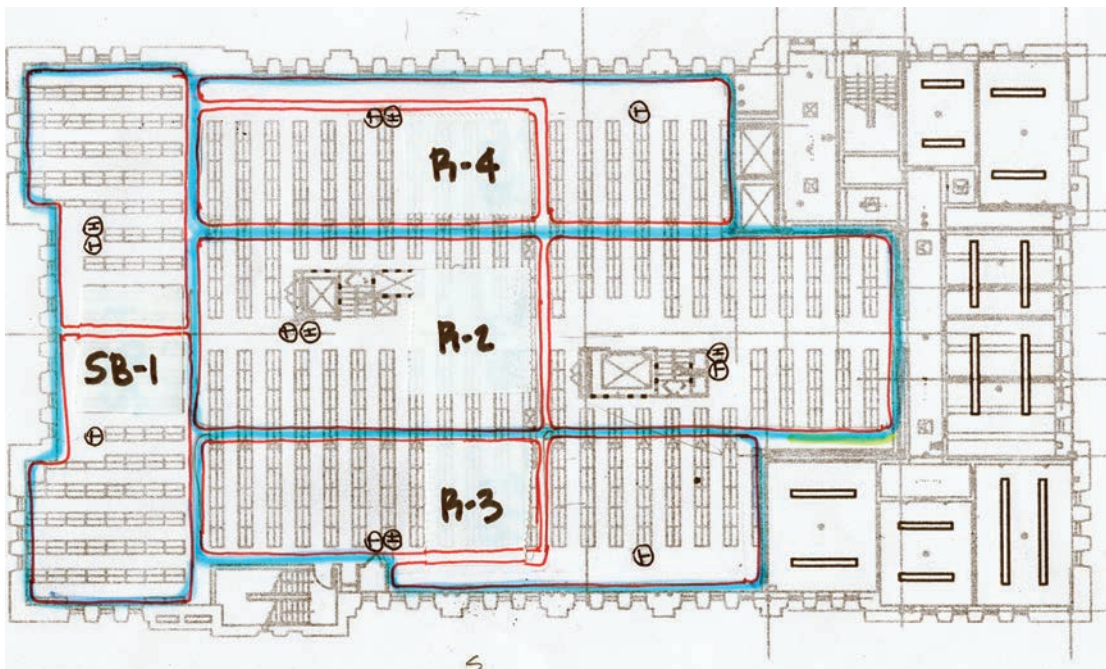

*Library floor plan indicating spaces served by four separate AHUs. The T and H notations on the drawing indicate the location of the temperature and humidity control sensors.*

In addition to storage areas and work areas, other useful information can be added to architectural drawings. You may want to note the location of the temperature and RH sensors that tell the AHU what to do, and the location of portable dataloggers that monitor space conditions. You can identify outside walls and the location of doors and windows, indicate the lighting layout in the space, or highlight the location of supply air fans.



Architectural floor plan indicating HVAC zones, logger locations, and other information

## 4B Create Schematic Diagrams to Document the Mechanical System

Most Class Four and Class Five buildings employ a moving stream of air to control the climate of storage spaces (see Section 2C). To fully understand how the storage climate is created it is important to develop a schematic understanding of the entire mechanical system, and this can be achieved by following the air stream loop from the point it leaves the storage space through the return air grills, along the return air path to the AHU, through the AHU, and returning through the supply air ducts to re-enter the storage space via the supply air grills.

To begin, simply draw a square representing the spaces served, and a square representing the AHU with lines representing the supply and return ducts to complete the loop. This is illustrated in the drawing on the top right.

When the details of the exact spaces served by the AHU are known, the schematic can be refined as shown in the schematic image on the lower right. This drawing shows the return air (RA), the place where relief air leaves, the place where outside air (OA) enters, and the supply air (SA) path to three locations (office, lab, and archives).

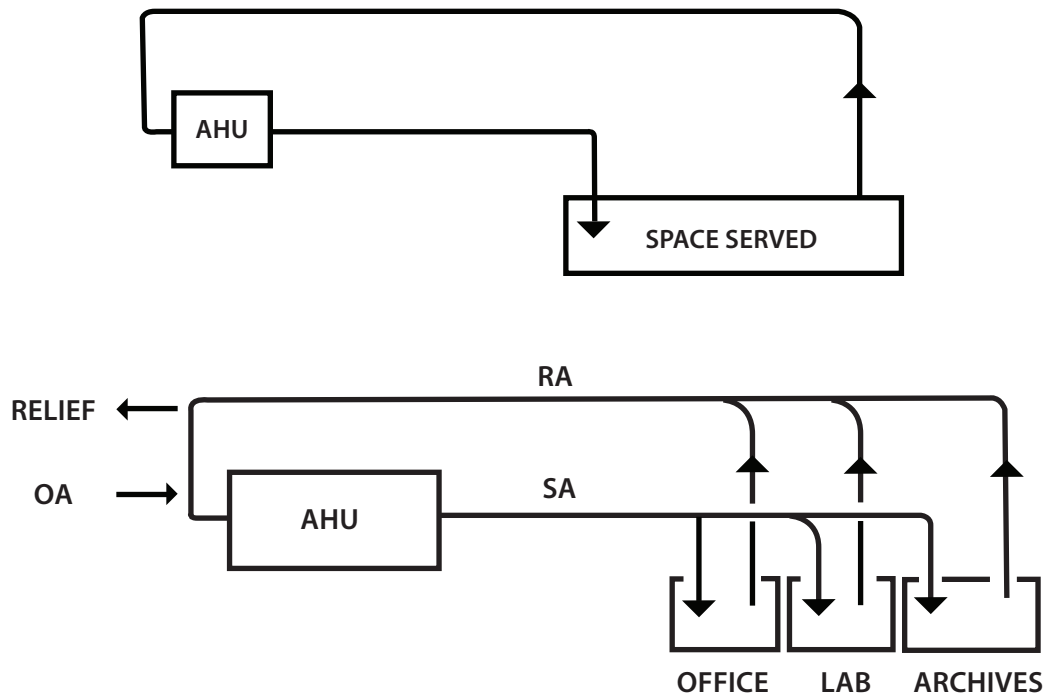

*AHU System Basic Schematic*

Finally, the components of the AHU itself can be inventoried and shown schematically in their appropriate location. The AHU detail in the schematic illustrated below shows what might be encountered while following an air path through an AHU. The outside air enters (A), passes through filters, a cooling coil (D), a heating coil (E), a humidifier (F) and a fan (G), and then leaves the AHU as supply air to the spaces. Many building management systems have graphics similar to this for each AHU. In such cases all that remains to be done is to create a graphic that shows all the spaces served by each AHU.

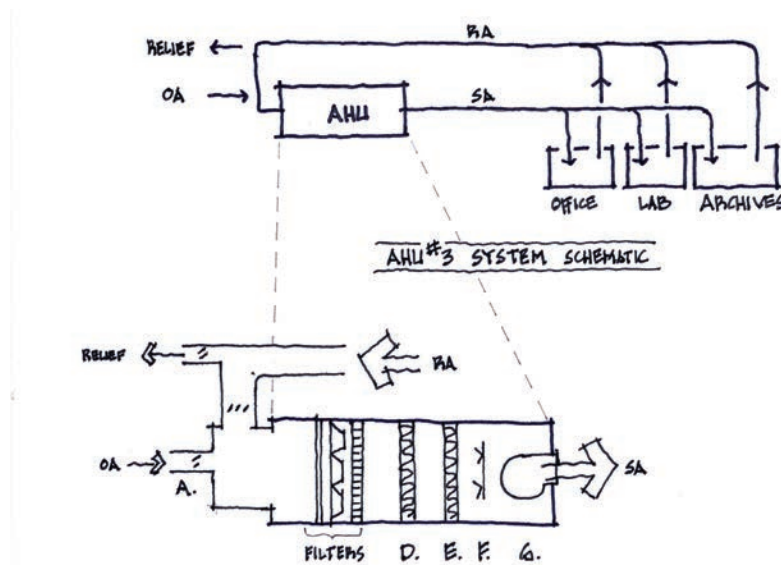

*AHU System Schematic with Detail*

Be forewarned that no two systems are exactly alike. The schematic shown at right, for example, appears similar to the system on the previous page. However, it differs in that the outside air enters in a location remote to the AHU, the supply fan is before the cooling and heating coils, and there is no provision for relief air.

System schematics are extremely useful tools. Developing these diagrams as a team is a great learning experience. Using the documents as a point of discussion allows all participants in environmental management (facilities management and operators, collections care staff, and administrators) to reach a shared understanding of how the climate is created, and promotes a fuller understanding of the system's overall capabilities.

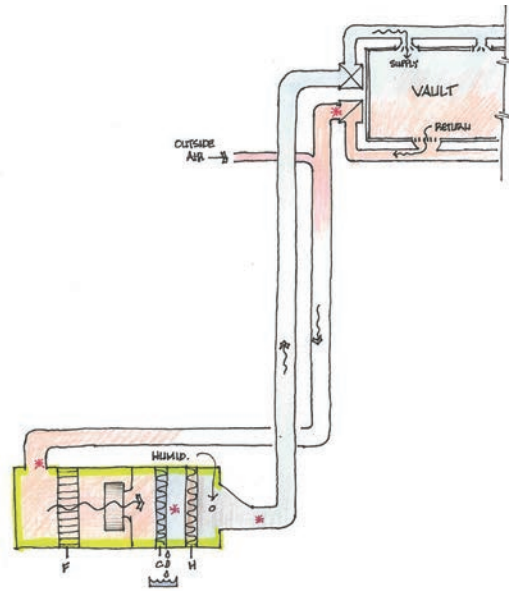

**See Section 4 for HVAC System Documentation Worksheets including a checklist of system components. These worksheets can be very helpful when documenting your mechanical system.**

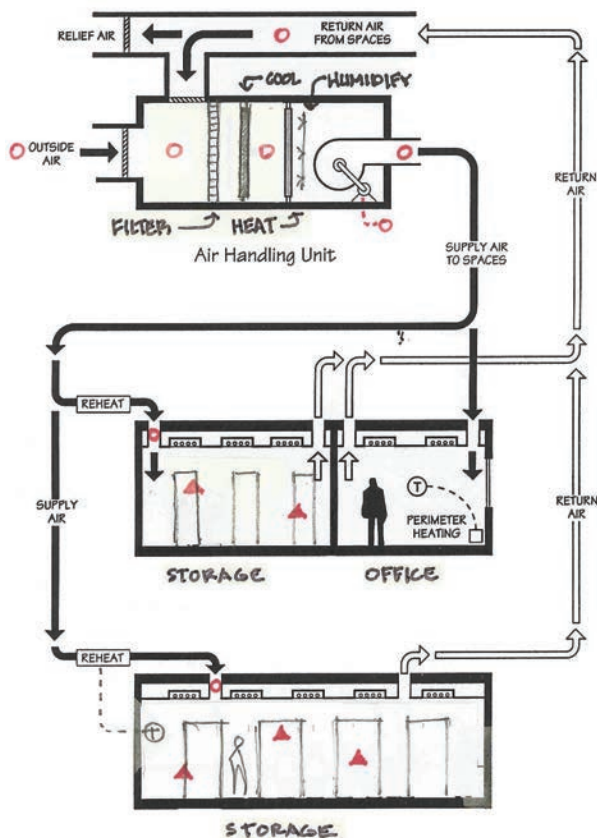

Later on additional information can be added to the storage area schematic, such as the location of the sensors that control the cooling coil and humidifiers, and information on how the quantity of outside air is controlled. The drawings can indicate which walls abut interior spaces and which are exterior and exposed to weather. All relevant documentation should be centralized into a file for each mechanical system and made available to the Environmental Management Team.

The schematic on the left includes a diagram of the AHU and follows the return air and supply air paths to office and storage spaces connected to that particular mechanical system. The room drawings include heat loads from both lighting and perimeter heating.



## 4C Identify Heat Loads and Sources of Moisture

Several factors unrelated to the climate control settings can influence the temperature and humidity in a given space. These are defined as heat loads and sources of moisture. It is important to identify the source and impact of these factors in collection storage and exhibition spaces.

Ernest Conrad, P.E., President, Landmark Facilities Group, Inc., has identified six sources of heat load. Review each of these and try to understand how they affect the environment in your building—particularly in areas that house and display collections.

### Solar

Heat energy from the sun, which enters the building through windows, doors and skylights.

### Transmission

Heat energy that moves through a wall or roof caused by a temperature difference on either side. This is most significant in the winter when the difference between the inside and outside temperature is greatest.



### Lights

Lights and other electric devices (computers, copiers, etc.) which contribute heat energy when they are running.

### People

People produce a heat load which is about half water vapor and half warmth. This can vary with the temperature of the room (hotter room – more water output). Unless the room is crowded with people, the influence is small.

### Infiltration

The movement of moisture laden air from one space to another, such as air moving through an opening or through porous materials.

### Minimum Outdoor Air

The outdoor air mandated by building codes which must be introduced into all occupied spaces for indoor air quality purposes.

Excess moisture has a major impact on collection preservation. Building-related problems that can raise the level of relative humidity within a structure include:

- roof, ceiling, or window leaks
- gaps in walls, floors, or foundation vapor barriers
- leaking plumbing
- damaged gutters and downspouts
- trees and shrubs close to the building which retain moisture
- wet walls and foundations from poor drainage
- deteriorated brick or masonry
- open water sources such as sinks or toilets
- high levels of ground water, underground streams, nearby ponds

Incorporate notes about these problems into your floor plans and related documentation for easy reference during analysis.

Stefan Michalski, Senior Conservation Scientist with the Canadian Conservation Institute (CCI), created the drawing on the right to help historic house staff identify sources of incorrect RH around their sites and buildings (left half of drawing) and their control (right half, with an asterisk).

- A. surface moisture - \*improve drainage above ground
- B. moisture in soil - \*improve drainage below ground
- C. rainwater - \*add gutters, downspouts
- D. hot attics - \*add roof ventilation, floor insulation
- E. exterior walls - \*keep collections away, add insulation
- F. heating systems - \*don't block vents and returns

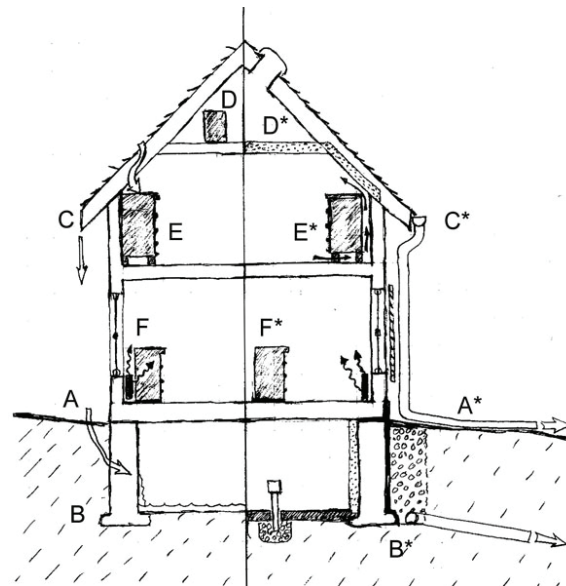

Source: *Incorrect Relative Humidity*

URL: <http://www.cci-icc.gc.ca/caringfor-prendresoides/articles/10agents/chap10-eng.aspx>, Department of Canadian Conservation Institute, 2011. Reproduced with the permission of the Minister of Public Works and Government Services Canada, 2012.

Documentation of the mechanical systems that serve your collections storage and exhibition spaces is a very important element of achieving an optimal environment for preservation. System documentation can:

- Facilitate communication and a shared understanding of the functions and capabilities of the HVAC system for the entire Environmental Management Team
- Uncover previously unknown system malfunctions
- Identify opportunities for energy savings
- Allow for realistic goal setting

## CHAPTER 5: Understand the Role of Dew Point

As we noted in Chapter 1, the dew point determines what combinations of temperature and RH will be possible in the storage environment. At a constant dew point, when the temperature goes up, the RH goes down and when the temperature goes down, the RH goes up. Therefore, the dew point is responsible for determining which temperature setting will give you which RH. Controlling the moisture content of the air—the dew point—is key to managing the risk of material decay. Collections care and facilities management staff should review the following questions:

- How does your mechanical system manage temperature?
- How does your mechanical system manage relative humidity?
- What is the dew point temperature throughout the year and how is it managed?

Remember that the Dew Point Calculator ([www.dpcalc.org](http://www.dpcalc.org)) can be used to determine what combinations of temperature and RH are possible for your storage areas given the dew point temperature you have to work with.

In buildings with humidity control, the dew point of the indoor air is controlled by the building's mechanical system. When outdoor dew points are high and the air is warm, you need a system that can both cool the air and wring the moisture out of it. Simply cooling the air isn't enough; without dehumidification, the moisture level indoors will be much too high. When outdoor dew points are

### **Quick Facts:**

- Dew point represents the absolute moisture content of the air.
- Dew point determines which temperature will give you which %RH.
- If your building does not have humidification or dehumidification, the indoor dew point is the same as the outdoor dew point.
- If your building has cooling-based dehumidification, the indoor dew point temperature is within a few degrees of the temperature of the cooling coil of your mechanical system.

low, you need a system that can add moisture through humidification. In order to change the dew point of the outdoor air, the mechanical system must have the capacity to add or remove moisture.

If your collections are in a building with no humidity control system (which is the case for many historic buildings) you can't change the dew point temperature of the outdoor air. The only method available to you to control moisture in the air is through temperature regulation. As noted previously, temperature, relative humidity and dew point are interrelated—you can lower RH by raising the temperature or raise the RH by lowering the temperature.

## 5A Managing Dew Points in Practice

Almost every engineer, facilities manager, or building operator will say that the most challenging aspect of managing preservation environments is moisture control, which really means dew point control. A thorough understanding of the ways in which moisture control is achieved—or not—is a basic requirement for sustainably managing preservation environments. This is because adding or removing moisture from air can be very costly and wasteful of fossil-fuel-derived energy. Temperature control is much easier to obtain in real-world situations than humidity control. However, humidity control is vitally important for preservation.

### Raise the Dew Point and Humidify the Air

There are two basic methods for mechanical systems to humidify the air and raise the dew point. One, steam (water vapor) can be introduced into the air stream. Low-pressure steam created by the mechanical system is injected into the air stream as the last stage in conditioning the supply air within the AHU. Two, evaporate liquid water directly into the air stream. This occurs when liquid water is atomized into the air stream by being forced through a small nozzle, or when it is evaporated from a cascading stream of water or from a foam pad. Because evaporation of water consumes heat, this method cools the air as well as humidifying it.

### Lower the Dew Point and Dehumidify the Air

There are two basic methods for mechanical systems to dehumidify the air and lower the dew point. One method is to sub-cool and reheat. Sub-cooling followed by reheating is the most common method of dehumidification in large building systems. This method involves cooling the air to the desired dew point temperature and then reheating it to the desired temperature. Passing air over a cooling coil whose surface temperature is below the dew point of the moving air stream causes condensation, which drips off the coil and runs down a drain. Air leaving the cooling coil has a lower moisture content than before, but it is also cold and has an RH near 100%. This is why it must typically be reheated, raising its temperature and lowering its RH, before it is delivered to the building spaces.

Less common but recently gaining in popularity, a second method of dehumidification uses a desiccant wheel. Desiccant dehumidification makes use of the property of some chemical substances (silica gel, lithium chloride) to absorb moisture from the air at moderate temperatures, and then to release that moisture when heated to high temperatures. Desiccant dehumidification systems typically involve passing air over a moving, honeycombed wheel containing water-absorbing chemicals. As the wheel rotates, it

then passes through a separate stream of heated “regeneration” air that is vented to the outdoors. This “regeneration” stream causes the chemicals to release the moisture so by the time the wheel completes a revolution, the chemicals are again ready to absorb moisture.

## 5B Understand the Moisture Content of the Air

Peter Herzog, of Herzog/Wheeler and Associates prepared the following information for use during the Sustainable Preservation Practices workshops presented in 2010-11 to help participants develop their understanding of dew point:

**Concept A:** The capacity of air to hold water increases as air is warmed, and decreases as air is cooled.

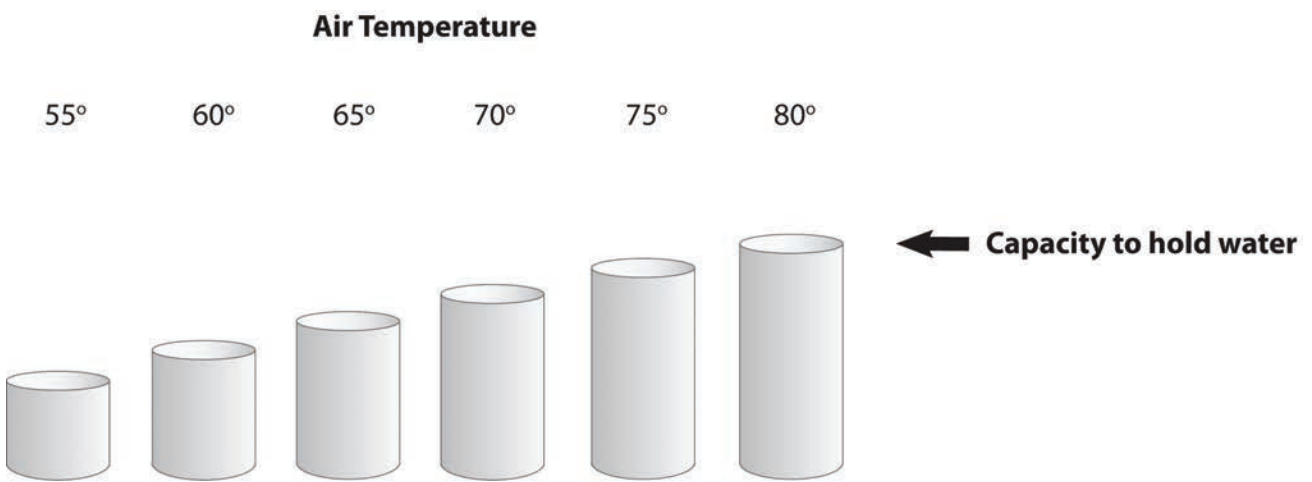

Figure 1: Visualize the water-holding capacity of air as a container that grows larger when it is warmed, and smaller as it is cooled.

**Concept B:** The actual amount of water in the air does not change with changes in air temperature.

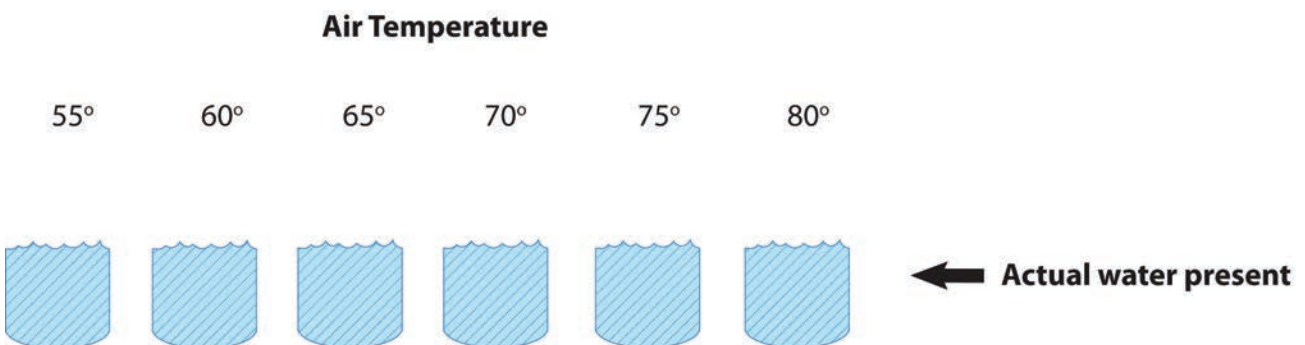

Figure 2: The actual amount of water in the air is called absolute humidity and can be expressed as a ratio of pounds of water in each pound of dry air.

## Concept of Relative Humidity

We can combine Concepts A and B to illustrate the concept of relative humidity. For an example, we have chosen the absolute humidity of 0.0092 pounds of moisture in each pound of air.

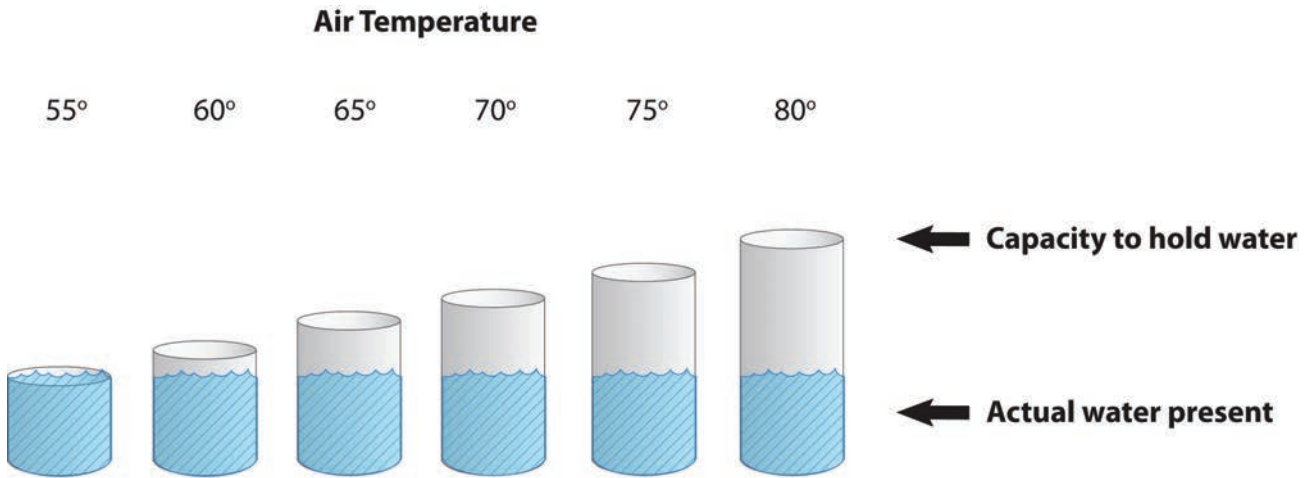

Figure 3: The relationship between the moisture-holding capacity of air at various temperatures and the actual amount of moisture present in the air.

Note that at 75°F the amount of moisture present represents one-half (50%) of the air's water-holding capacity at that temperature. The amount of moisture present relative to the amount the air can hold at 75°F is 50%...the relative humidity of that air is 50%.

At 60°F, the container (moisture-containing capacity) is about 85% full, illustrating that air of our example absolute humidity would have a relative humidity of 85% if cooled to 60°F.

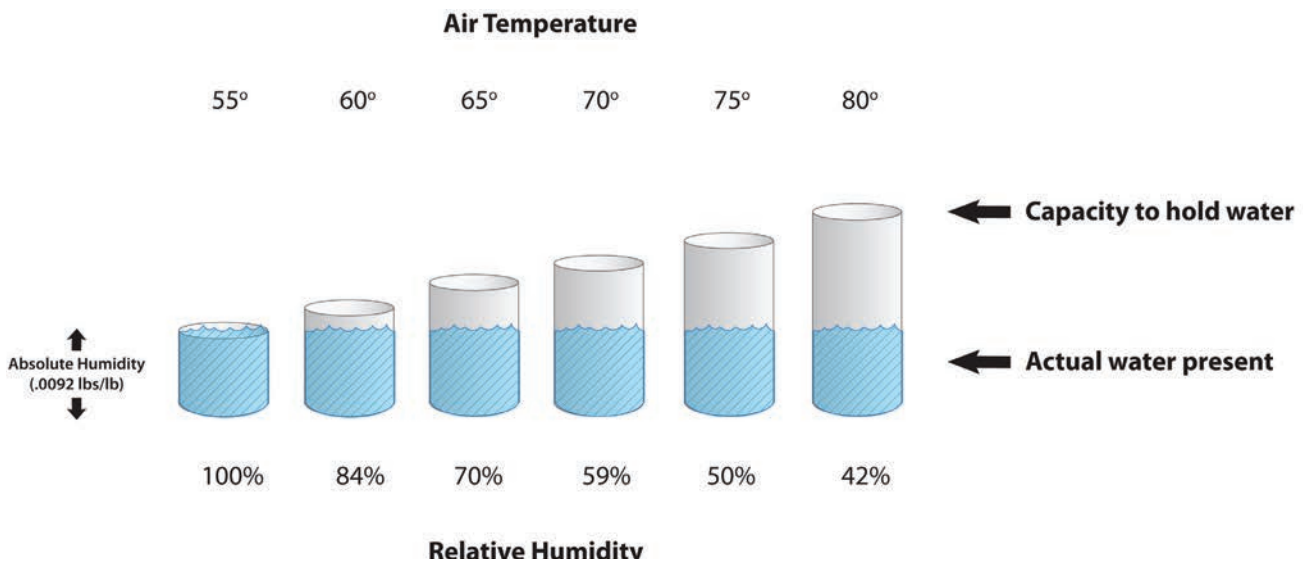

Figure 4: The relationship between air's capacity to hold moisture and its temperature, absolute humidity and relative humidity.

As Figure 4 illustrates, air of an absolute humidity of 0.0092 pounds of moisture per pound of dry air will be saturated (reach its dew point) at 55°F. Therefore an indirect way of describing the absolute humidity of the air would be to say: "Air with this much moisture in it would reach its dew point at 55°F".

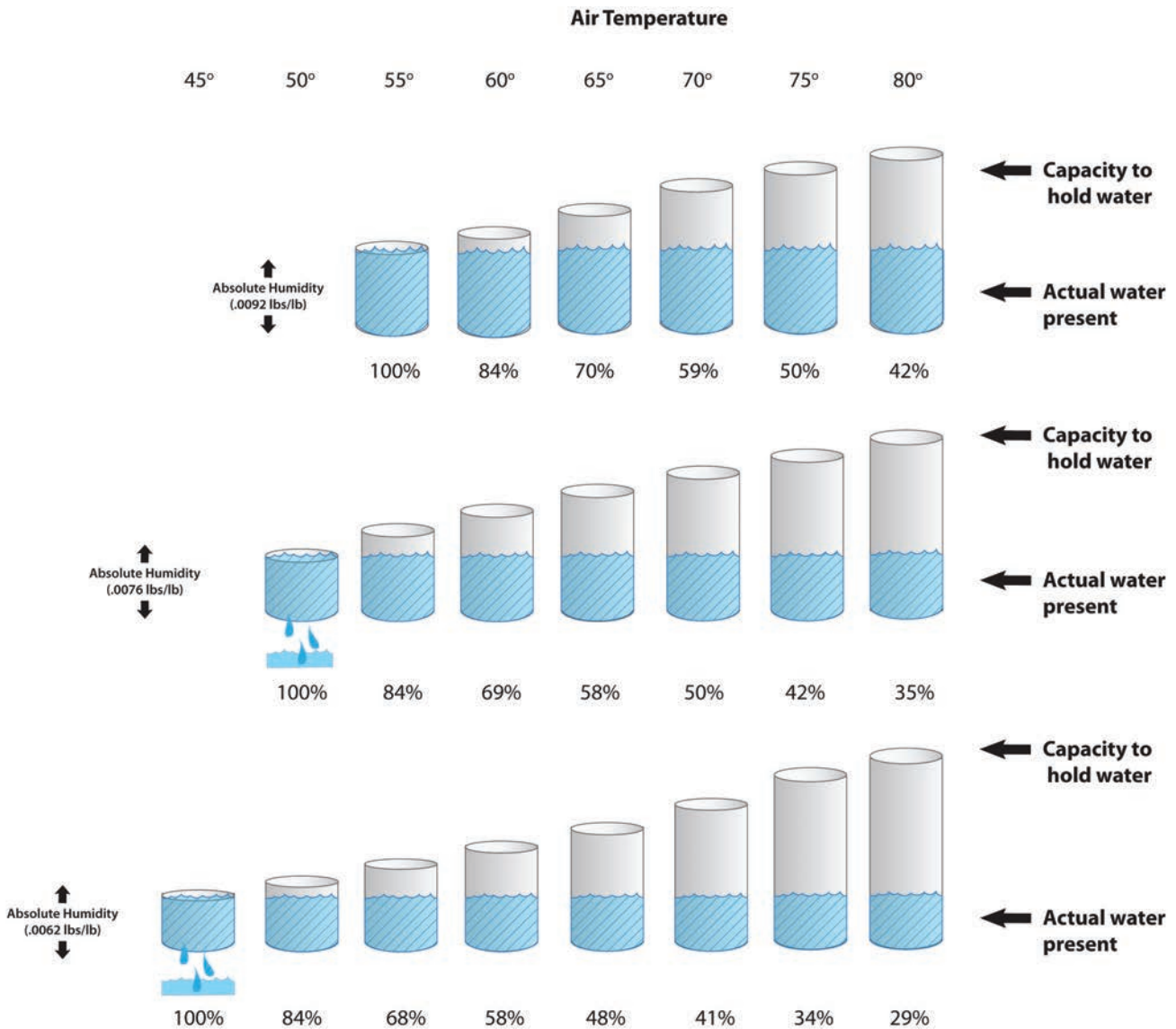
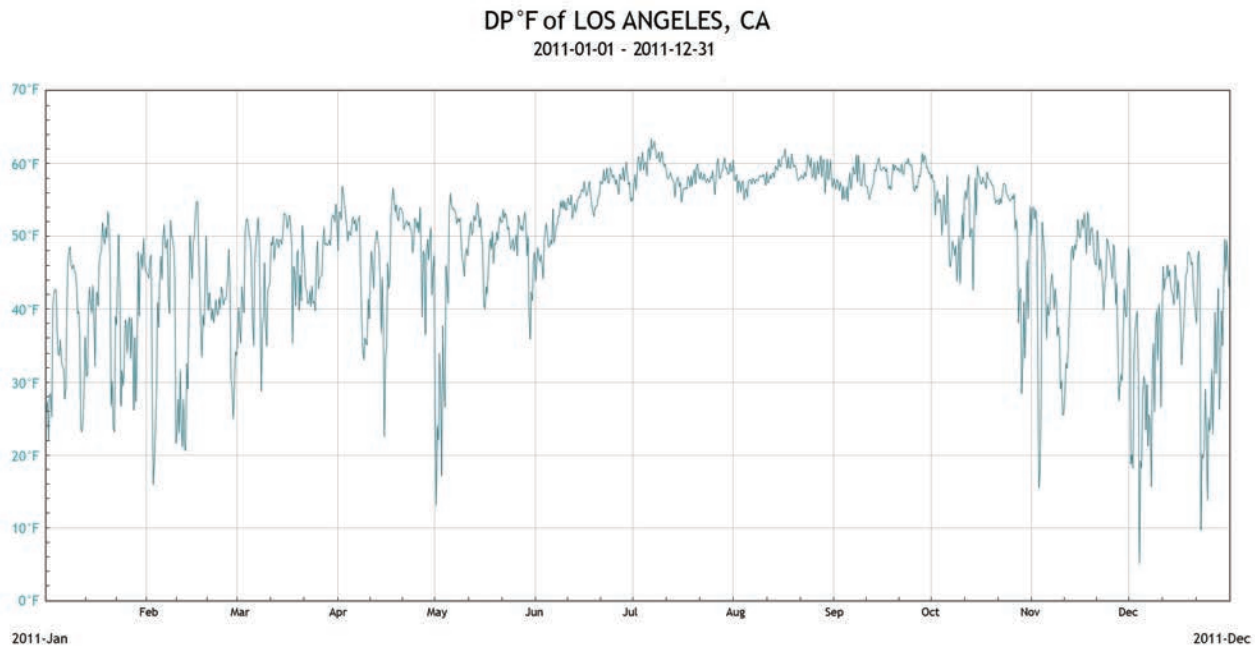

Figure 5: The absolute humidity/relative humidity/temperature relationships for air with a range of absolute humidities.

Note that each absolute humidity has a corresponding temperature, at which that air would be saturated, and water would begin to precipitate out or dew would form; i.e., its dew point temperature. Reading top to bottom, the three absolute humidities shown have corresponding dew point temperatures of 55, 50 and 45°F.

For most climates, the outdoor air moisture content (absolute humidity), and therefore its dew point temperature, is constantly changing. It is not uncommon for outdoor dew point temperatures to range

seasonally from a high of 75°F to a low of 5°F. The dew point temperature in Los Angeles has a smaller range; rarely going above 60°F or below 25°F. This is illustrated in the following graph.



Take a close look at the annual dew point temperature for your regional climate. Anytime outside air is brought into a storage space and the dew point temperature (absolute humidity or moisture content) is higher than the desired condition, moisture will have to be removed from that air. Similarly, any time outside air is brought in when its dew point temperature is lower than the desired condition, moisture will need to be added.

## Example of Cooling Coil Dehumidification

We can use Figure 5 to illustrate how all of these concepts are applied to the common process of removing moisture from air (dehumidification) using a cooling coil.

Assume that the entering outside air is 75°F and 50% relative humidity, and  
Assume the desired storage space condition is 65°F and 50% relative humidity

Consulting Figure 5, we observe the following:

- The outside air at 75°F and 50% RH has an absolute humidity of 0.0092 lbs. per pound of air and a corresponding dew point temperature of 55°F.
- The desired space conditions of 65°F and 50% RH has an absolute humidity of 0.0062 lbs. per pound of air, and a corresponding dew point temperature of 45°F.
- The outdoor air clearly contains more moisture than the desired air conditions, indicating that some moisture must be removed.





## CHAPTER 6: Analyze Collected Data

In Chapter 3 we discussed the collection of temperature and humidity data and pointed out that gathering data is just a means to an end. The goal is to get meaning from the data through analysis. Accurate data and reliable analysis can provide the basis for many collection management and all environmental management activities. The ability to achieve an optimal and sustainable environment for preservation depends heavily on your ability to draw meaning from collected data.

### 6A Use Environmental Data to Manage the Environment for Preservation

What do you want the collected temperature and humidity data to tell you? How much information can a hygrothermograph give you about the preservation quality of the location being monitored? Short-term graphs may be useful if you work with temperature and relative humidity targets—either you are in or you are out—but can you determine the significance over time of the short term deviations you see on the charts? Can you determine how the environment will affect the collections stored in the space? We now know, based on decades of research by preservation scientists, that the previously accepted norm—that temperatures should be steady at a human comfort level and short-term fluctuations in relative humidity matter more than long-term trends—is outmoded and counterproductive. Setting targets for an ideal environment and reacting to daily or weekly excursions is the wrong approach.

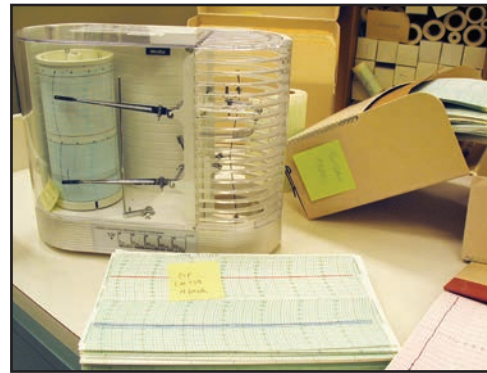

A better approach is to analyze collected data and use the analysis to:

- Identify decay risks – chemical, mechanical, biological
- Compare the preservation quality of one space to another
- Determine which space is best suited to the long term preservation of various materials
- Review the preservation quality of a particular location from one year to the next
- Document the capabilities of your HVAC system and identify any malfunctions
- Identify and document the need for HVAC system improvements
- Evaluate the effect of changes in HVAC operation and their effect on collection preservation and/or energy-saving approaches

A raw data table, which lists the frequent readings of temperature and RH taken by a datalogger or by the Building Management System, can be useful. However, the amount of data can be staggering and analysis of the data table cannot provide quick and reliable answers to the questions we have about the environment.

If you are relying on data from your Building Management System, remember that the control system requires set targets and tolerances for T & RH that are programmed in. These targets then form the basis for analysis of collected data and limit analysis to determining whether or not and how often the environment stayed within prescribed limits.

Data graphs add some dimension to the data and provide better visualization of change over time. If your software program allows, graphs can be used to compare spaces and view change over time. If you overlay outdoor data and dew point graphs you can learn a lot about the capabilities and functions of your mechanical system. Most electronic datalogger software will provide graphs and statistics.

For effective environmental management, you need to analyze the effects of environmental conditions on collections, which is more complex than understanding time in and out of an “ideal” environment. To meet this need, the best approach is computational analysis. In this approach, calculations are performed on the raw T & RH data in order to estimate the preservation risks or benefits to collections. One advantage of computer analysis is standardization, which removes the subjective aspect of data interpretation. Another is the ability to produce quantitative measurements of the effect of actual environmental conditions on the rate of material decay and the preservation of collections.

## 6B Use IPI’s Preservation Metrics™ to Analyze the Risk of Material Decay

In study after study, IPI observed that heat and humidity were the primary drivers of most forms of decay. Although the importance of temperature and relative humidity had been well documented in the research community, there were few resources available to help preservation staff understand the impact of real-life environments on collections. Recognizing the need for a way to transform data into tools that are applicable to the management the environment for preservation, IPI developed Preservation Metrics™.

Preservation Metrics™ transform temperature and relative humidity data into quantitative numerical measures of collection decay risk. IPI developed metrics for chemical change in organic objects, dimensional change or mechanical damage, the potential for biological decay or mold risk, and moisture-induced corrosion. Each metric evaluates the quality of environments over a period of time into a single value representing the degree of risk for a particular form of material decay, taking into account all the ups and downs of T and RH during the monitoring period. To use the metrics effectively, you simply need to understand what forms of decay they address and what the numeric values tell you about the preservation quality of the space.

IPI’s Preservation Metrics™ were developed to provide quick, automated analysis of environmentally-induced decay. They allow you to accurately and objectively determine how well each storage area is performing for collection preservation, how well one environment is performing compared to another, and how various collection materials are faring in a particular location. Metrics can flag potential problems and document the impact of changes or adjustments made to improve conditions. Analysis based on metrics can be used to argue for funding or other resources needed to make improvements in storage conditions.

## Natural Aging – Assess the Risk of Chemical Decay

### PRESERVATION INDEX (PI) AND TIME-WEIGHTED PRESERVATION INDEX (TWPI)

- Vulnerable collections include all organic materials such as paper, wood, textiles, plastics, leather, dyes, etc. Fast decaying organic materials include acidic paper, color photographs, and cellulosic plastics

Environments influence the rate of natural aging (spontaneous chemical reactions within organic materials and with air and moisture) by providing heat energy and moisture, which is a reactant in many decay reactions. Therefore temperature (T) and relative humidity (RH) are key determinants of the rate of this kind of deterioration. Every combination of T & RH is associated with an overall rate of chemical decay. IPI developed a table which assigned values (Preservation Index or PI) to every such combination of T & RH. The higher the PI value, the longer it will take for a given amount of decay to occur.



If environments stayed at the same T & RH all the time, PI would be all you need to know to describe the environment's effect on chemical decay. But environments vary, so you need a way to integrate ups and downs over time. During warmer and moister periods, collections deteriorate faster. During cooler and drier periods, they deteriorate slower. To account for this, when you consider how PI values 'average' out over time, you have to properly 'weight' each unit of time in the overall calculation of decay rate. That is why the most useful metric for chemical decay is the Time-Weighted Preservation Index (TWPI). It's best used when looking at a full calendar year of data because it properly weights a cool winter with a warm summer. This is why review and analysis of a full year of data, covering all seasons of the year, is most reliable.

TWPI applies to all organic materials and is the most significant preservation metric for book and document collections. TWPI values are very useful in determining which spaces are best for storing vulnerable organic materials. TWPI is best interpreted not as a prediction of lifetime but in a relative fashion. For example, if room A has a TWPI of 50 and room B has a TWPI of 100, it means that the reactions of decay are happening twice as fast in room A than room B. Interpreting the TWPI metric is simple – higher numbers are always better.

<b>TWPI &gt; 75</b>	<b>GOOD – slow rate of chemical decay in organic materials</b>
<b>TWPI 45 – 75</b>	<b>OK – generally OK but fast decaying organic materials will be at elevated risk</b>
<b>TWPI &lt; 45</b>	<b>RISK – accelerated rate of chemical decay in organic materials especially for fast decaying organic materials</b>

## Mechanical Damage – Assess the Risk of Dimensional Change

### EQUILIBRIUM MOISTURE CONTENT (%EMC) AND DIMENSIONAL CHANGE (%DC)

- Vulnerable collections include composite objects such as rare books, paintings, furniture, musical instruments, tools, etc. Sensitive or fast responding hygroscopic material can include paintings, rare books, vellum manuscripts, inlaid wood, or musical instruments

Wood, paper, textiles and many other hygroscopic (water-absorbing) materials change size and shape depending on how much water they contain. These are physical or mechanical behaviors (in the sense of not involving any chemical change to the material) that can harm collection objects. These reactions are dependent mainly on the profile of RH over time. The preservation risks to hygroscopic materials are most acute during periods of extreme dryness or dampness, and when large excursions between these extremes occur.

IPI modeled the metrics for the physical/mechanical risks to collections posed by environmental conditions on the behavior of an imaginary block of wood. The critical things to know are: How dry did it get, how damp did it get, and how large was the difference between those extremes? To answer the first two questions, IPI uses an estimate of the moisture content of wood derived from the actual observed T & RH data in the environment. This estimate of the moisture content of wood is expressed as Percent Equilibrium Moisture Content (%EMC). It is the percent by weight of water contained in the wood. If the wood were weighed, then dried by heating and weighed again, the difference in weight would be the water content.

To answer the question regarding magnitude of excursions from dry to damp, IPI estimates how much change in size (expressed as a percentage of original size) that the difference in moisture content represents. There are actually three separate metrics that matter in estimating physical risks to collections: How dry did it get is represented by the minimum %EMC observed in the data, how damp did it get is represented by the maximum %EMC, and the difference in size (based on how the water content of wood affects its expansion and contraction) is called Percent Dimensional Change (%DC). Interpreting the mechanical damage metrics may seem complicated at first, but remember what each metric represents and it becomes easier – you want an environment that is not too dry or too damp, with limited fluctuation between the two.

<b>Min EMC <math>\geq</math> 5% AND Max EMC <math>\leq</math> 12.5% AND %DC <math>\leq</math> 0.5%</b>	<b>GOOD – minimal risk of physical damage; not too dry or too damp, and almost no fluctuation between the two</b>
<b>Min EMC <math>\geq</math> 5% AND Max EMC <math>\leq</math> 12.5% AND <math>0.5\% &lt; \text{%DC} \leq 1.5\%</math></b>	<b>OK – not too dry or too damp and minimal fluctuation between the two, however sensitive material may be at higher risk</b>
<b>Min EMC <math>&lt;</math> 5% OR Max EMC <math>&gt;</math> 12.5% OR %DC <math>&gt;</math> 1.5%</b>	<b>RISK – heightened risk of physical damage; either too dry, too damp, or too much fluctuation between the two</b>

## Mold Risk – Assess the Risk of Biological Decay

### MOLD RISK FACTOR (MRF)

- Vulnerable collections – all organic materials including paper, wood, textiles, leather, etc., and inorganic materials with organic films.

To develop the metric for biological decay, data was analyzed to determine if environmental conditions promote biological decay, including the growth of xerophilic mold and mildew and the risk of insect infestation. IPI's analysis was based on empirical studies with food grains. The algorithm that creates the MRF value integrates over time, creating a running sum of progress toward mold germination. The MRF number represents the risk of mold germination and subsequent growth. 0.5 indicates that mold spores are half way to germination. Look for an MRF of 0.5 or less for an environment with little or no risk of biological decay. There is no OK rating for mold growth – either there is the potential for mold germination (RISK) or there isn't (GOOD). Alerting users of the potential for RISK allows time to react and take preventative action before any visible or vegetative mold appears.

<b>MRF <math>\leq</math> 0.5</b>	<b>GOOD – little or no risk of mold growth</b>
<b>MRF <math>&gt;</math> 0.5</b>	<b>RISK – environment with mold spores have germinated, entering a vegetative mold state and visible mold could be actively growing</b>



# Metal Corrosion – Assess the Risk of Metal Corrosion

## MAXIMUM EQUILIBRIUM MOISTURE CONTENT (MAX %EMC)

- Vulnerable collections include metal objects and objects with metal components (including some images, textiles, inks for example). Highly sensitive materials include archaeological or salt-encrusted metals.

The metal corrosion metric represents the degree environmental conditions promote moisture-induced corrosion in vulnerable metal objects. As with mechanical damage, analysis of T & RH data is based on a moving average of relative humidity levels. The algorithm incorporates two levels of severity based on adjusted RH. The metric used to indicate the risk of metal corrosion is Max EMC (excessive dampness). The metric numbers indicate the maximum level of moisture content in the environment.

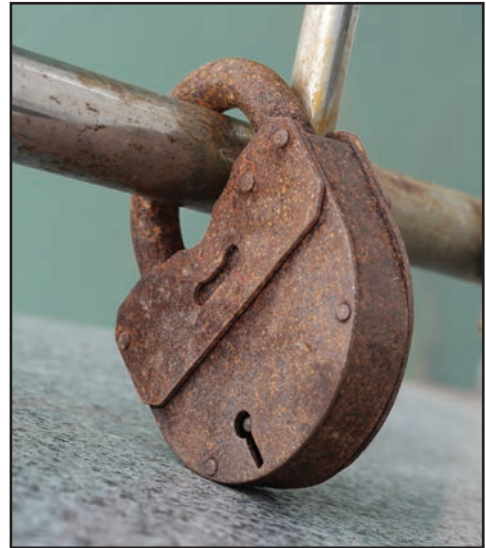

<b>Max EMC <math>\leq</math> 7.0</b>	<b>GOOD – minimal risk of corrosion due to excessive dampness</b>
<b>7.1 <math>\leq</math> Max EMC <math>\leq</math> 10.5</b>	<b>OK – limited risk of excessive dampness; however sensitive material may be at higher risk</b>
<b>Max EMC <math>&gt;</math> 10.5</b>	<b>RISK – risk of corrosion due to extended periods of dampness</b>

IPI's Preservation Metrics™ are based on decades of research. IPI has written about them in various publications and proven their usefulness and accuracy during field trials in many different institutions. Preservation Metrics™ are only available in the software and websites created by IPI.

## 6C Data Analysis and Mechanical System Performance

There are useful techniques in data analysis that can help you better understand the performance of your mechanical systems. A few of them are illustrated and explained below.

### Identify Periods of Humidification and Dehumidification

You can determine whether humidifiers are in use by overlaying a full year of indoor and outdoor dew point data on one graph. The graph below shows a location with no humidification or dehumidification. When no humidification is taking place, the indoor and outdoor curves will lie on top of each other, as they do in the first few months shown in the graph below (the fall season). During the winter season, the indoor dew point (in teal) follows the same pattern as the outdoor (in yellow) but doesn't quite reach the same extremes. It's normal for indoor dew points to remain a little higher than outdoor, even on cold days, because some moisture is released by water-absorbing elements of buildings and collections.

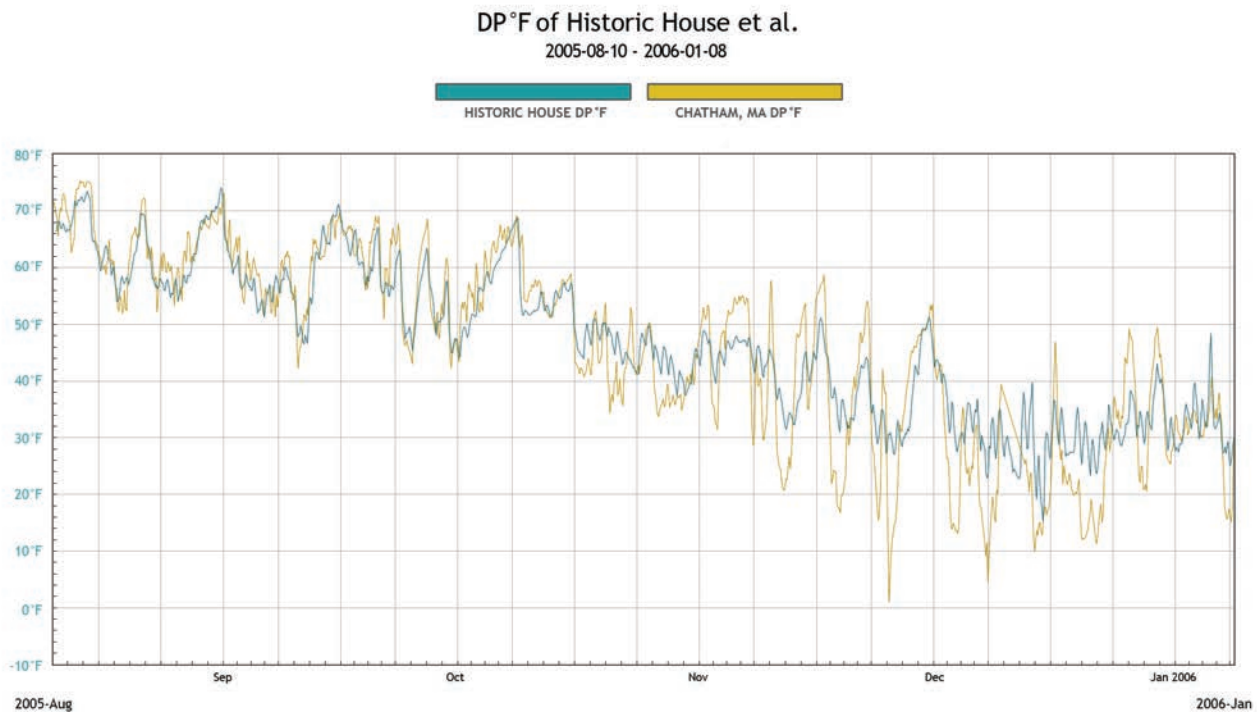

*Indoor and Outdoor Dew Point – No Humidification or Dehumidification*

If a humidifier is in use, the indoor dew point graph will have a “floor” (a level below which the dew point temperature will not go). The next graph of storage location data illustrates that humidification ran from January 2007 to April 2007, and again from late October through December, keeping the dew point temperature above 40°F. You can also see periods of dehumidification when the dew point is kept under 45°F from early June to early September.



DP °F of Special Collections Vault  
2007-01-11 - 2007-12-31

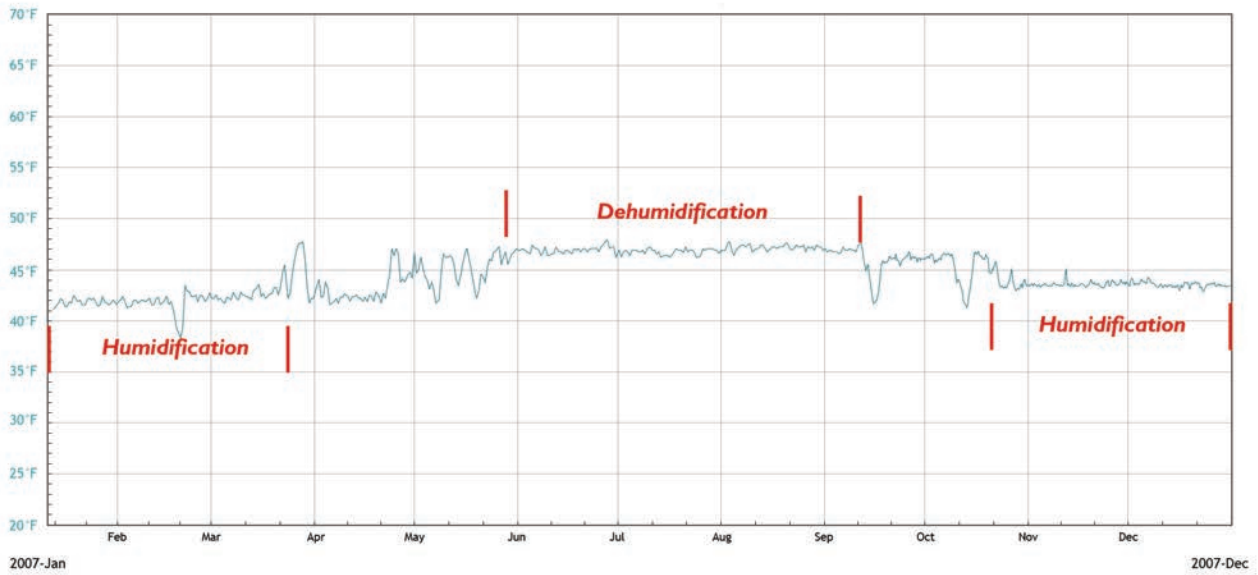

*Indoor Dew Point – Location with Humidification and Dehumidification*

The graph below shows a full year of indoor and outdoor dew point data for a space in Washington, DC. Note that although the indoor (teal) and outdoor (yellow) lines differ, the major outdoor ups and downs in dew point temperature do have some influence on indoor conditions.

DP °F of Music Room et al.  
2010-01-01 - 2011-01-01

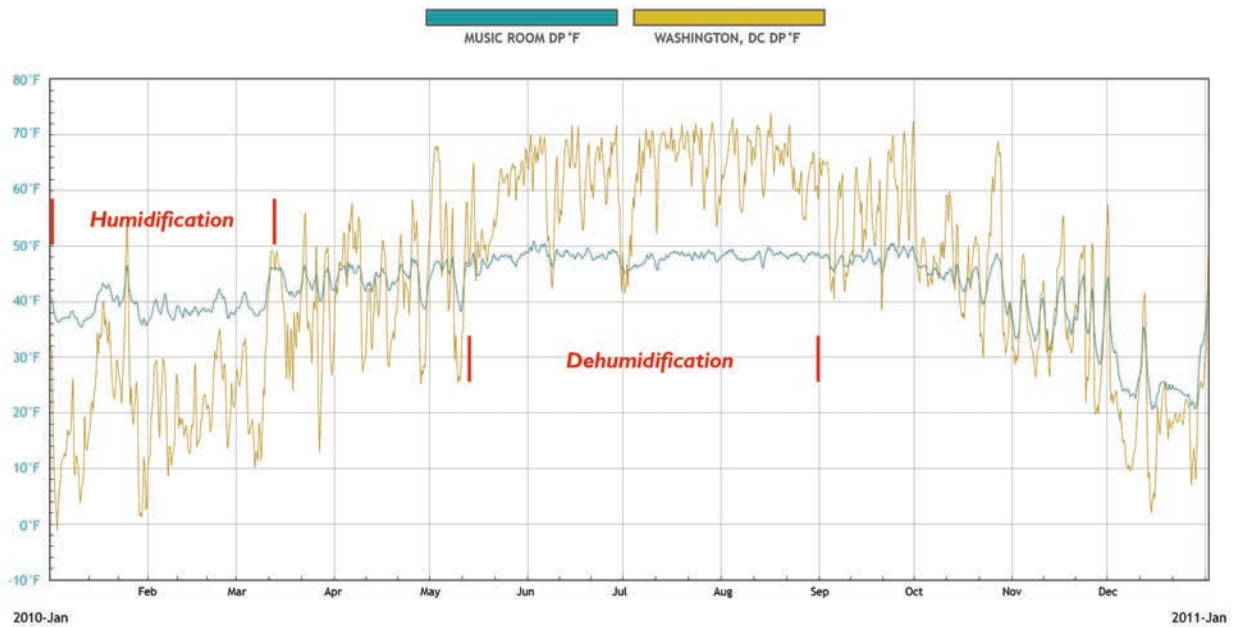

*Full Year of Indoor and Outdoor Dew Point*

During the winter months of January through late March, the outdoor dew points are fairly low, much too low to provide an appropriate RH when the air is heated to room temperature. The indoor dew points are higher, moving around a bit but mainly staying in the range of 30-40°F. This indicates that the mechanical system serving this space is humidifying the air.

In the summer months (May through September in this location) outdoor dew points are consistently higher than indoors, indicating that dehumidification is taking place. The blue line shows that indoor dew points average near the high 40°s and are relatively well controlled within a narrow range. When the indoor summer dew point line is fairly flat, that is evidence that the mechanical system is asserting control and regulating the indoor dew point. From the preservation point of view, this is good news, because in many cases properly managing the indoor summer dew point is the key to reducing the rate of natural aging. For preservation, cooler and drier is better, and a low summer dew point allows you to have both cool temperatures and moderately low RH's, which will improve the TWPI—and thereby reduce the rate of chemical decay. Finally, the DP graph from late October through December shows a lack of humidification, as the indoor dew point drifts downward.

There are periods during the 'transition' months (March through May, and October and November) when the indoor and outdoor dew point lines lie on top of each other, and near the desired range of 35-45°F. During these times, no humidification or dehumidification is apparently going on, nor is any necessary—but just in case it might be, this would be a good time to check that energy is not being wasted by the systems acting like they do during the summer, sub-cooling and re-heating air to remove moisture that isn't really there in the first place. Such unnecessary work done on outside air can add up to very significant energy costs.

## Determine Which System Serves the Space

Analysis of dew point graphs from different locations during the same time period can help to clarify which mechanical systems affect a particular location. Although they may share the same source of outside air, two AHU's usually do not do exactly the same amount of humidification or dehumidification. This means that their plots of dew point temperature over the course of time will not be exactly the same. Often this fact can help separate which space is served by which AHU. Consider the following graph of three locations in the same building served by two different systems:

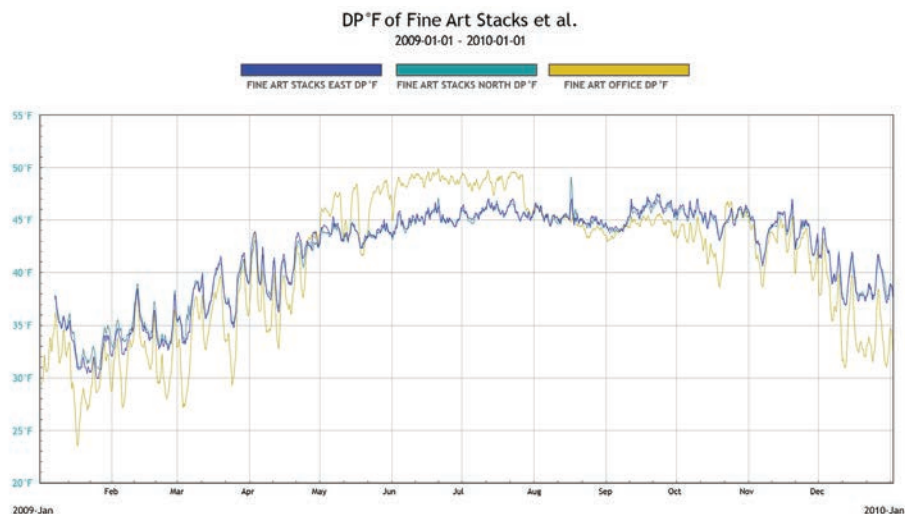

You'll notice that the yellow line has an entirely different shape than the blue and teal lines, which are almost identical. This indicates that the space represented by the yellow curve has either a different AHU serving it, or else shares the same AHU but has additional equipment that modifies the air before reaching the space.

## Identify Night Time Setbacks and Lighting Schedules

The next graph shows temperature from one storage location over several weeks. Notice that the days of the week are indicated at the bottom of the graph – each vertical mark indicates one 24-hour period. The saw tooth pattern seen in this graph is typical in spaces where temperature settings are lowered or AHUs are shut down during evening or unoccupied hours, then raised again, or where lights go off at night and on again in the morning.

Remember to keep the temperature range on the Y axis of the graph in mind when you see this—the swings illustrated in this graph actually fall within a 4 degree range. Magnifying the graph makes the changes seem disproportionate but helps illustrate the daily fluctuations.

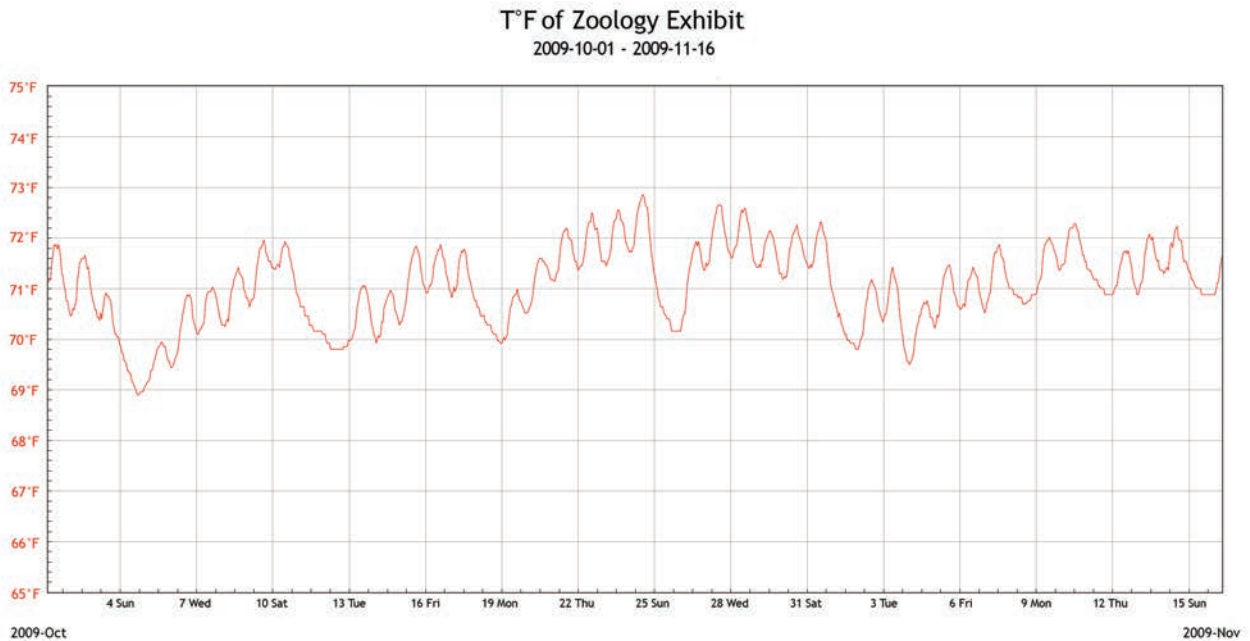

*Temperature Readings over Several Weeks in One Location*

## Track Changes in Humidification and Dehumidification

Analysis of dew point graphs from storage locations can determine whether or not your mechanical system is providing adequate humidification during the winter heating season, or dehumidification during the summer. You can identify which spaces are humidified or dehumidified, when the system kicks in, and if system settings have changed over time.

The following graph shows the dew point temperature in one space over several months—including two winter heating seasons. During the first winter (December 2008 through March 2009) the dew point temperature is maintained around 48° - 49°F. Compare this data to that gathered during the same period in the following year. Clearly no humidification is in place in 2010 since the dew point temperature dropped to 35°F or less in December and even lower over the next few months.

This graph illustrates why it is best to gather and analyze environmental data over a long period of time. Mechanical systems break down, settings are changed, other incidents occur and without accurate data you can't identify or address issues that affect preservation. It also illustrates the need to create an Environmental Management Team to analyze data, identify sub-optimal conditions, and institute operational changes.

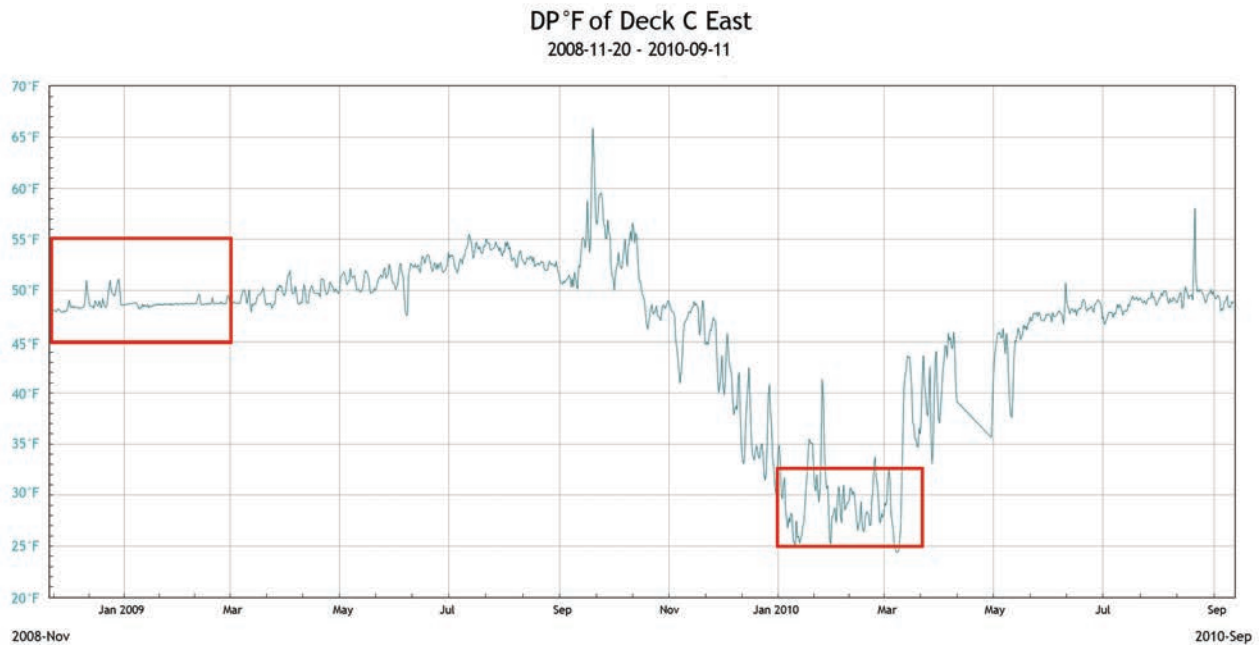

*Changes in Dew Point in One Location through Two Winter Seasons*

# SECTION 3: INSTITUTE SUSTAINABLE PRESERVATION PRACTICES

## MAINTAIN AN OPTIMAL AND SUSTAINABLE PRESERVATION ENVIRONMENT

### Section Three includes three chapters:

- Chapter 7: Create an Environmental Management Team
- Chapter 8: Specific Activities of the Environmental Management Team
- Chapter 9: Investigate Opportunities for Energy Savings

These chapters cover the steps involved in the process of instituting and maintaining effective environmental management in your institution including specific responsibilities and activities that will lead to an optimal and sustainable environment for preservation.

The final section of this guidebook includes additional information you can use to guide your institution toward sustainable preservation practices.

## CHAPTER 7: Create an Environmental Management Team

7

An ongoing, meaningful collaboration between facilities, collections, and administrative staff is the most effective way to achieve an optimal and sustainable environment for preservation.

Perhaps the single most important step toward this goal is the creation of a team within your institution to jointly address and negotiate the task of environmental management. The key stakeholders in creating and maintaining the environment should be represented on the team. These stakeholder groups include the people who provide the environment (facilities staff, building operators, energy and sustainability managers), the people who have preservation responsibility for the collections (conservators, preservation staff), the people who work in the building to perform its mission (collections and service staff, curators, librarians, etc.), and of course, the people who are responsible for the administration and finances of the institution (directors, administrators, budget officers).

The recommendations included in this chapter, as well as the other chapters in this section, are based on IPI's lengthy experience in developing and working with cross-disciplinary teams in a variety of institutions. The process began in 1997 while working with the Library of Congress and The New York Public Library on Optimizing Collection Life and Energy Costs in Cultural Institutions, a project funded by the Mellon Foundation. Projects involving optimization have continued at both of these institutions since that time. IPI has experience working with environmental management teams in small libraries, historical societies, records offices, research and public libraries, as well as major institutions like the National Museum of Denmark and the Folger Shakespeare Library. Although every organization is unique, there are enough common elements that the suggestions in this guidebook can be successfully adapted by any institution.

## 7A Develop an Effective Environmental Management Team

*"An ongoing dialog between preservation and facilities, having the right players and accurate data, and following through – all are essential to the team process. We have fine-tuned our trouble shooting process and looked closer at equipment functionality thanks to this opportunity to look at systems holistically."*

*M. Hassan Kholdi, CEM, PE  
Senior Project Manager & Energy  
Liaison Office at The New York  
Public Library, and Member of  
IPI's IMLS-Funded Energy Saving  
Opportunities Project team, 2009-  
2013*

Every decision about environment and facilities affects multiple aspects of institutional life (human comfort, collection health, budgets). That's why it's so important to put together a cross-disciplinary team. The most effective teams are not large groups, but do have a few motivated individuals who recognize the mutual benefits of the team process and have the trust of people in the departments they represent (in other words, they have the power to follow through on team decisions). It can be beneficial to have an individual leader or champion who will insure that the team is designed to be inclusive, that the group meets together frequently, and that decisions are made and followed up on.

IPI's experience shows that it tends to work best if the collections care function takes the lead in assembling and championing the team. The facilities representative on the team should have enough authority to carry out team decisions. The administrative representative has to let all staff know that the activities of the Environmental Management Team are important and that their decisions carry weight.

Relevant data and incident information should be brought to the Environmental Management Team meetings. These meetings should be scheduled at regular intervals, and have agendas and minutes. Activities can include data review and comparison, identification of underperforming spaces, determination of summer and winter settings, and review of adjustments, failures, etc.

Environmental management is a process—it isn't fixed, it's managed. The process must be routine and ongoing. The temptation to believe that everything is operating as well as it can and that there is no need to devote resources to examining operations with a critical eye is very common and almost always wrong.

In reality:

- Mechanical systems are prone to sub-optimal operation – settings change, equipment malfunctions, and unexpected incidents occur
- Sub-optimal operation can and does persist undetected and/or uncorrected

The graph below illustrates several years of collected data from one location. You can see that although the space maintained the dew point temperature above 40°F most of the time between 2000 and 2005, the system failed to do so starting in 2006 and got worse from then on. During an Environmental Management Team meeting this graph would be shared, discussed, and analyzed. The team would work to identify what caused the change (system malfunction, set point change, miscommunication, etc.). Solutions for alleviating the problem would be developed and a schedule for instituting a correction would be set. During a follow-up meeting the team would see what affect any actions taken would have on the environment and on the long-term preservation of collections.

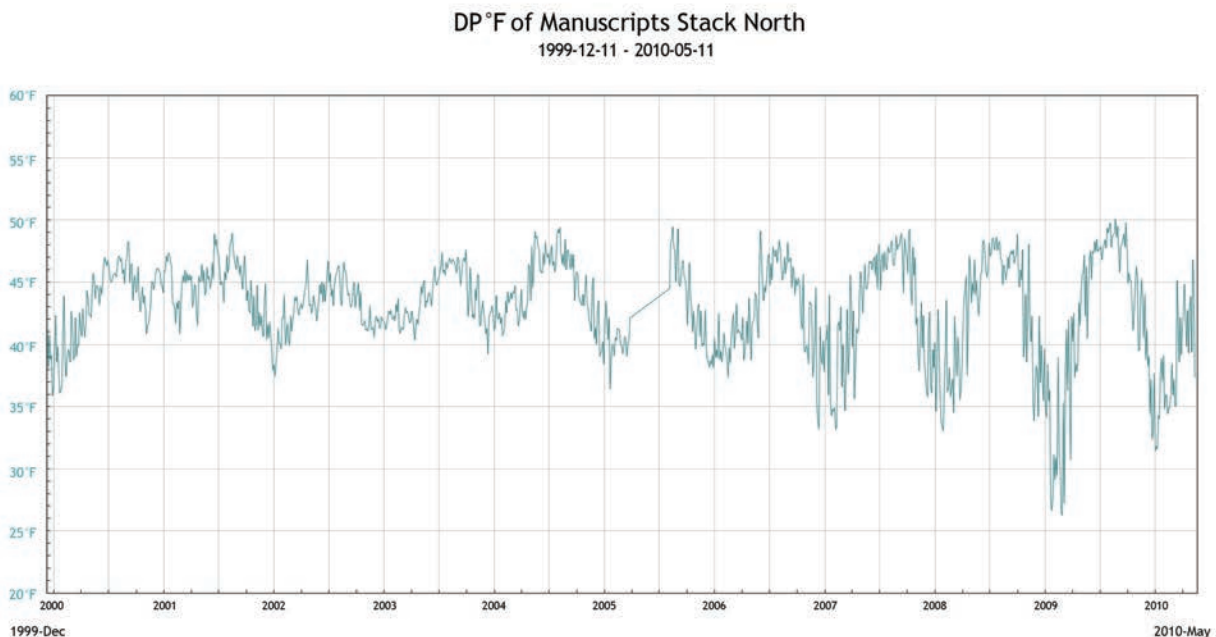

The people who affect the storage climate are numerous, are not connected by any organized structure, and answer to different “masters”. The most successful environmental management programs will be those where the process is institutionalized, with mandate and support from the administration. It is important to have a staff member or a position dedicated to the tasks and responsibilities of monitoring and analyzing the environments, and a committed facilities staff capable of enacting necessary changes.

Success relies on a strong working relationship between departments – the most committed preservation staff member will not be able to enact meaningful change in the system that produces the storage environment if facilities staff will not respond. Likewise, facilities staff will have a much easier time carrying out sustainability measures if they can work with collections staff to determine an optimal environment that saves energy without causing additional harm to collections. A mandate from the administration to work together to achieve this goal will expedite the process.

With this level of teamwork, the management of storage environments becomes much less reactionary and far more strategic. Collections staff benefits through better storage planning, facilities by helping to prioritize maintenance and capital expenditures, and the administration through efficient operation of the institution.

## 7B Define the Broad Responsibilities of the Environmental Management Team

Once you have an Environmental Management Team with the appropriate resources and skills committed to the task, regular meetings and ongoing communication is essential. The factors affecting storage climates (weather, HVAC equipment, control systems, occupant behavior, etc.) are variable and prone to malfunctions that typically go undetected. You can't take a "fix it and forget about it" attitude. You need a well-defined process for dealing with both short and long-term environmental issues. Based on work with the Library of Congress and other colleagues, IPI and Herzog/Wheeler & Associates determined that managing the environment for preservation over the long-term must be based on the following key capabilities:



1. The ability to measure the actual storage climate over time in each area where significant collections are housed (this requires dataloggers and a data management system).
2. The creation and maintenance of documentation defining the optimal (best achievable) climate for all seasons of the year for each area (this is based on team review of appropriate data and negotiation based on factual information).
3. The ability to define an optimal environment for various storage locations and collection types.
4. The ability to regularly download reliable storage climate data, to compare the actual situation to the best achievable, and to detect and report when sub-optimal (harmful or wasteful) climates occur.
5. The ability to diagnose and correct the cause of sub-optimal climate conditions and to take actions that will reduce the likelihood of the malfunction's recurrence.

These key capabilities are discussed in more detail in Sections 8A and 8B of this guidebook.



## Cultural Differences and Potential Setbacks

Team members involved in managing the environment for preservation need to diplomatically educate each other and the people they represent to the range of views involved in the process. They should establish relationships in which cooperation and a shared responsibility for collection longevity cut across functional and organizational units. There will be difficulties as these different “cultures” begin to work together. These groups tend to function very differently and rarely together. When working as a team, some defensiveness and resistance may be encountered, but it should be made clear that each team member brings necessary expertise and their input is appreciated.

Although preservation and collections staff are used to meetings and discussions, building operators and HVAC technicians are not. It can be difficult to get facilities people together in a meeting unless it is short and action-driven, not a lecture or presentation. They are often tied to their buildings and the tasks of the day and may only get involved if their supervisors attend the meeting or let their staff know the topic is important. It may be difficult to find someone who knows, or can understand, the mechanical system holistically. Facilities staff are expected to be problem-solvers focused on the most pressing concern of the day. They are not usually asked to look at or analyze long-term trends.

Collection care staff needs to understand that recent preservation research has fundamentally altered basic approaches to the temperature and relative humidity conditions recommended for collection storage. The old paradigm of defining target temperature and relative humidity settings with limited fluctuation is deeply ingrained in both collection and facilities staff. Changing this outlook requires a re-education process.

Administrative staff should support and encourage the activities of the Environmental Management Team. Allow team members the time to attend regular meetings and follow up on actions taken by the team. Encourage members to work together productively to develop a clear path to problem resolution. Support the development of procedures for responding to complex and/or chronic mechanical system problems that require analysis and thoughtful resolution.

## CHAPTER 8: Specific Activities of the Environmental Management Team

The ultimate goal of the Environmental Management Team is to achieve an optimal environment for preservation—which we have defined as an environment that achieves the best possible preservation of collections at the least possible consumption of energy, and is sustainable over time.

You have achieved an optimal and sustainable storage environment when your existing mechanical system consistently produces the best possible storage environment it is capable of, with the least possible consumption of energy. In other words, do the best that you can with what you have.

### 8A Define the Optimal Storage Environment for your Institution in Six Steps

There are six primary steps the team should take to define what an optimal storage environment is for

your institution. There may be some variance depending on the systems serving a particular space or the type of collections contained in a space. The steps include:

## Step 1 – Document the capabilities and performance of your HVAC system

- Document what each system associated with collection storage is capable of
- Document the storage environment through reliable data collection
- Verify that each of these systems is operating optimally
- Correct any system malfunctions

Chapters 3 – 5 of this guidebook gave you the guidance you need for this step – reliable documentation of the storage environment, an understanding of your climate control system, and an understanding of the role of dew point. The preparation required for this step will take some time and effort, but it can be done concurrently with the steps below.

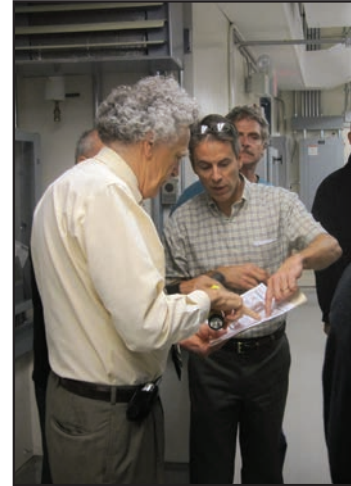

## Step 2 – Define the environment that is best for collections

- Temperature requirements
- Relative humidity requirements
- Acceptable range of T and RH fluctuations
- Potential for different settings based on the heating and cooling seasons

Chapter 1 of this guidebook provided information on the basic elements of the environment and their effect on material decay including material types, modes of decay, and the role of environment in decay. Information in Chapter 2 will help you determine the potential for different settings given your region and the type of mechanical system you have.

## Step 3 – Determine the environment acceptable to occupants

- Do union regulations apply?
- Does work take place within the storage area?
- Can work activities be separated from storage spaces?
- What are the occupant schedules within collection spaces?

This information will be unique to your institution and underscores the need to include team members, at least temporarily, who can provide reliable answers to these questions.

## Step 4 – Negotiate the optimal environment for each storage area based on:

- HVAC system capabilities
- What is best for the collections in the space
- What is acceptable to staff and occupants

Information provided in Chapter 6 will help the team define optimal conditions for storage and display environments in your institution.

## Step 5 – Express the optimal environment in measurable metrics

By working as a team you will be able to successfully express and communicate your definition of both optimal mechanical system performance and optimal conditions for long-term collection preservation.

## Step 6 – Regularly measure the “actual” environment, compare those results to the “optimal” environment you have defined, and promptly correct any malfunctions

This step incorporates ongoing team activities which are detailed in Section 8B.

The goals of this process are to understand what the mechanical systems are supposed to do (what they are capable of), to document and examine what they are actually doing, and to correct sub-optimal operation. Sub-optimal operation results in inappropriate levels of material decay as well as excessive or unnecessary use of energy. Looking at these operational issues as a team will often result in a better environment for long-term preservation at a lower energy cost.

### **Questions the Environmental Management Team should consider:**

1. What climate is the existing system actually delivering on an annual basis?
2. What climate is the existing system capable of delivering on an annual basis?
3. Are all elements of the system functioning as they should? (Systems are prone to sub-optimal operation, which can persist undetected and/or uncorrected unless each of the elements is actually checked.)
4. Who within the institution can request a change in climate settings that impact the storage environment? Who can make these changes? Are changes documented?
5. Is the current process for instituting set point changes in keeping with goals for maintaining an environment for preservation?
6. Is the system consuming more energy than necessary to deliver the actual climate?

7. What steps need to be taken to improve the environment for preservation?
8. Will these steps increase or decrease energy use?
9. Does the institution have a formal process for managing the storage environment?
10. What procedures would ensure continual optimal operation?

## 8B Maintain Optimal Storage Environments in your Institution

The effort of managing the storage environment and continuously managing risk may seem onerous on the surface. However, the effort will pay off in the long run, and once fully instituted can save a considerable amount of both staff time and energy costs. Ideally, preservation staff will understand when a situation truly requires attention and worry less about minor fluctuations or short spikes in temperature and RH. In addition, facilities staff may be able to defer responding automatically to human comfort calls and focus on staying within realistically defined temperature and humidity parameters. Ongoing environmental management is also preferable to dealing with seasonal mold outbreaks or paying for treatment of damaged collections.

### Ongoing Environmental Management Team Activities

As we've noted, environments change and fluctuate continuously and monitoring should be continuous whenever possible. It is important to meet as a team regularly to review unexpected changes, malfunctions, or sub-optimal operation. Conditions and priorities change, equipment will wear down or break, changes in adjacent parts of the building may impact your space, or different storage locations may require special attention. The team should routinely deal with problems that arise and develop proactive solutions that minimize damage, use energy efficiently, and maintain efficient system operation.



Once optimal conditions for preservation and mechanical system performance have been defined, team focus can turn to maintenance activities as outlined in Step 6, Section 8A (p.70) of this guidebook. Some of these tasks are detailed below.

### Identify and Correct Sub-Optimal Operation

- Compare the actual environment to your defined optimal environment:
  - Decide when to do a comparison—identify the most critical times and set up a schedule for review
  - Compare key measurable metrics—temperature, relative humidity, dew point, and if available, IPI Preservation Metrics™

- Promptly correct any deviations:
  - Consider the long-term effects of deviations from optimal environment
  - Work closely with facilities team members to develop effective solutions

Some of the sub-optimal scenarios you may encounter and their potential causes include:

**Storage space warmer than necessary - potential causes:**

- Inappropriate set point selection
- Supply air set point increased due to occupant complaint
- Supply air set point inexplicably increased
- Winter control schedules operating in summer
- Reheat coil malfunctions
- Adjacent space too warm
- Supply air path blocked

**Storage space more humid than necessary - potential causes:**

- Cooled air set point higher than necessary
- Malfunctions in chilling system, resulting in elevated dew point temperature
- Insufficient reheating
- Unnecessary humidifier operation

**Storage spaces drier than necessary - potential causes:**

- Insufficient maintenance of humidifier
- Humidifier disabled
- Excess outside air in winter

## Communicate Effectively

It's important for Environmental Management Team members to communicate new standards and procedures to other people in their departments. This is particularly true for individuals who have access to any part of the mechanical system. We've seen furniture placed on top of return air vents, valves forced shut or blocked, doors which should remain closed left open all day, etc. As the team takes action to

improve the environment they will have to enforce changes such as seasonal set points, reduced lighting schedules, night time shutdowns, closing of windows and doors, etc. Educating staff about the reasoning behind these changes and the ultimate goals of preservation and energy savings is essential.

## Prevent Inappropriate Adjustments

Human comfort requests should not be the only driver for set point changes – particular in systems that effect collections storage areas. Facilities must continue to inform and educate their staff since they will be on the receiving end of comfort complaints. Often a change made to a set point for one location will affect several others. Your institution’s HVAC zone map can be used to ensure that everyone is clear about which systems create environments for collections storage in order to avoid changes that work against the optimization goals of the team.

The Environmental Management Team should determine who has the authority to change temperature and humidity set points and to suggest procedures for handling requests for these changes. As the team gains experience, they may also define seasonal changes in operation such as instituting winter or summer control schedules.

# 9

## CHAPTER 9: Investigate Opportunities for Energy Savings

As stated in the introduction, collecting institutions are dealing with mandates to lower operating costs and institute sustainable energy use practices while maintaining long-term preservation of collection materials. This guidebook is designed to help institutions by providing guidelines and methods to avoid risks to collections while instituting energy saving practices. As we have already noted, the best solutions require input from collection care, facilities, and administrative staff as they work together to develop the optimal situation.

The complexity of the investigation of energy saving opportunities will depend on the size of your institution and the type of building and mechanical equipment you are dealing with. The suggestions included below are broken down based on the building classifications discussed in Section 2B.

### 9A Energy Saving Suggestions for Class One, Two, and Three Buildings

These building classifications are associated with both standard historic houses and some residential, and religious buildings. Moisture control is generally limited.

#### Reduce heating and cooling loads

Use shutters, windows, porches, curtains, awnings and shade trees. Pull down the shades on sunny summer days to reduce the heat load. Consider adding storm windows to reduce heat loss. You can

improve energy efficiency by using appropriate weather stripping and caulking around doors and windows. Consider installing insulation in attics and basements. Add insulation and vapor barriers to exterior walls only when it can be done without damage to historic building structures.

## Minimize lighting operation

When the room is unoccupied, lights should be off. Make sure that emergency circuits are kept to the minimum necessary. If lights are on motion detectors or timers, make sure that the length of time the lights are on corresponds with the average length of time spent in the space. Minimize equipment operation – for conditioned spaces or zones that include a large number of workstations with electronics (computers, copiers, scanners, etc.) be sure to shut equipment off at night and on the weekend.

## Lower the temperature where collections are housed to reduce energy use

Dial down the radiators or close the heat vents in winter—but measure the relative humidity to be sure it stays below 55%, in which case you will need to raise the temperature or dehumidify. Check the outdoor dew point averages and use IPI's Dew Point Calculator ([www.dpcalc.org](http://www.dpcalc.org)) to determine what the best balance you can achieve is. You will want to keep the RH between 25% and 55% to avoid the majority of moisture-related problems.

## Deal with any sources of moisture that could cause problems for your collections

Consider the effect of periods of high humidity, rain, local bodies of water, wet ground, leaking pipes and broken gutters, moisture in walls, human respiration and perspiration, wet mopping, flooding, and cycles of condensation and evaporation. Reduce or eliminate these problems to the degree that you can.

## Minimize infiltration through the building envelope

Keep doors and windows closed – not only windows and doors to the outside, but interior windows and doors that open between spaces served by different systems with different set points.

### **Manage RH in Historic Buildings**

*Initial steps to reduce relative humidity in historic buildings are not at all expensive. Move water away from the building by installing gutters and downspouts, slope the ground away from the foundation, and trim vegetation to at least two feet away from the building.*

*To avoid dangerously low relative humidity levels—below 20%—close your historic house museum from December through March and turn the heat down or even off for these months if water can be turned off and pipes drained. As the temperature decreases, the RH increases, so reducing the temperature from 65° to 55°F will increase RH from a dangerous 20% to a much safer 33%—and you will save on heating bills.*

*High humidity can be reduced in historic house museums in the spring and fall by controlling the furnace with a humidistat instead of a thermostat. For example, if RH goes above 55% the heat will turn on and run until RH drops back down to 55%.*

*Richard L. Kerschner, Chief Conservator, Shelburne Museum, Vermont*

## 9B Energy Saving Suggestions for Class Four and Five Buildings

Over a decade of experience in monitoring the behavior of storage area HVAC systems in Class Four and Five buildings and monitoring climate conditions in associated storage areas has demonstrated that these systems can consume more energy than necessary to achieve their desired climates, and that this excess energy consumption can go undetected by normal operating and maintenance practices. You can benefit by visiting each significant energy-consuming element and asking, “Is this element using any more energy than necessary to achieve its intended function?”

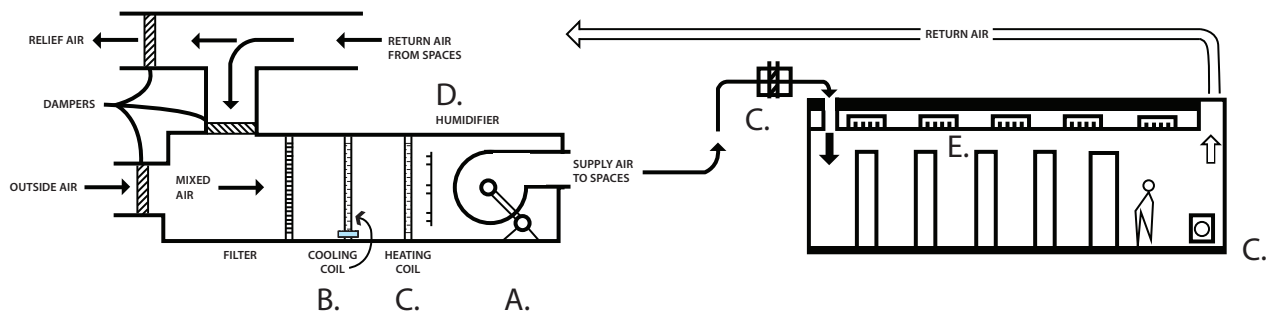

*A. Air Handling Fans B. Cooling Coil C. Heating Coil D. Humidifier E. Lighting*

The figures in the table at the right were included in Section 2D. They are repeated here to illustrate the allocation of annual energy cost in a typical collection storage area. Potentially excessive energy use by the system components (identified in the illustration above) are detailed below:

Component	% of Annual Energy Cost
A. Air handling fans	19%
B. Cooling coil	30%
C. Heating coil	40%
D. Humidifier	5%
E. Lighting	6%

### AHU Supply and Return Fans (A)

Many fan motors are equipped with variable speed drives, making it possible to reduce the fan speed (and therefore the rate of energy consumption) at times when the climate can be maintained with a reduced air flow. However, this variable capacity is often underutilized or not used at all. In situations where the fan speed can be controlled by a schedule (e.g., slowed down at night) the schedule is either not used at all or used too conservatively (e.g., slow down 10% for 3 hours per night when conditions could have been maintained by a slowdown of 50% for 8 hours per night). To get the maximum energy savings from this variable speed capability, facilities staff and collection managers must perform a series of experimental slowdowns to determine when (what time of day, what time of year) and how far the fan speed can be reduced without compromising the quality of storage climates.



## Cooling/Dehumidifying (B)

The function of the cooling system is to remove heat that enters the system. Within the storage spaces, heat is added to the air stream by the lights, and operation of the lights should therefore be managed to coincide with occupancy (see E. Lighting). Likewise, doors to adjacent warmer spaces should be open only when necessary.

For most Class Four and Class Five buildings with a reasonably constructed envelope, the primary driver of cooling energy consumption is the amount of outside air brought into the system. The introduction of more outside air than is necessary into a system, whether by holding to occupied building code for unoccupied spaces, through malfunction, or other cause, results in greater energy usage to perform work on that air. Whenever the outside air temperature is above the desired supply air temperature (usually 60°F or lower) heat must be removed. Additional heat must also be removed whenever the dew point temperature of the outside air is above the desired storage area dew point temperature (typically 45° to 50°F). In warm humid climates, the outside air needs cooling continuously, and even cool northern climates must cool outside air up to six months per year.



*Cooling Coil*

Most systems remove the excess moisture from outside air by a process of sub-cooling and reheating and this sub-cooling can represent a major portion of the total annual cooling energy consumption. Excess energy consumption occurs when sub-cooling is done when it is not necessary and/or when more air is sub-cooled than necessary (see C. Heating for an elaboration).

## Heating (C)

The temperature set point in many storage areas is determined by the temperature that must be maintained to prevent high humidity during summer months. Maintaining this temperature in winter may require heating that could be reduced or avoided if the temperature was allowed to drift lower in winter. A very large fraction of storage area heating energy is consumed in reheating air that has been sub-cooled for dehumidification. While this process may be necessary when the dew point temperature of the outside air is above the desired dew point temperature of storage spaces, this sub-cooling and reheating is not necessary when the outside air dew point temperature falls below the desired storage space dew point. Many systems sub-cool and reheat continuously all year, even in climates where it is unnecessary for several months per year.

Some systems are designed to allow a certain adjustable fraction of the air stream to bypass the sub-cool and reheat coils, thereby reducing energy use in situations and/or seasons when conditions can be maintained without processing all of the air. Many of the systems could increase the amount of air bypassed without compromising storage climates. Careful experimentation would likely show that this quantity could be increased during portions of the year, if not all of the time.

In many northern climates, heating needs are linked to the amount of outside air brought into the system. If the quantity of outside air exceeds the amount required, excess heating energy will be consumed.

## Humidifiers (D)

Humidifying typically represents a small fraction of annual energy use in storage areas and therefore offers few energy-saving opportunities. However, in northern climates where energy use for humidification is more significant, consideration should be given to the humidity set point in the space. Some facilities try to maintain 50% RH in winter, when a gradual seasonal drift from 50% in summer down to 35% in winter may not be detrimental to collections and will reduce humidification.

The amount of humidification required is directly related to the quantity of outside air introduced into the storage area mechanical system. Serious consideration should be given to how much outside air is brought in and when. Many systems bring in more outside air than is necessary all of the time, and most bring in more outside air than is necessary during periods when the collection storage areas are unoccupied.

## Storage Area Lighting (E)

The operation of any storage area lighting fixture when there is no one nearby requiring illumination can be considered a waste of electrical energy – both at the light fixture and at the cooling system that must remove the heat generated by this fixture. The occupancy of most storage spaces is very intermittent and an organized and sustained effort to prevent the unnecessary operation of storage area lighting fixtures will reduce energy consumption. The quantity of lighting in some storage areas is excessive, also, in which case consideration should be given to removing some fixtures.

## Summary of Class Five and Six Building Energy Savings Opportunities

The paragraphs above describe how each energy-consuming component of a storage area “system” can use more energy than is necessary to maintain the desired climate conditions. They demonstrate that excess energy use does not announce itself and show that energy use reductions will probably result if each energy-consuming component is carefully examined to see if the way it actually operates coincides with the way it needs to operate to maintain the desired storage climate.

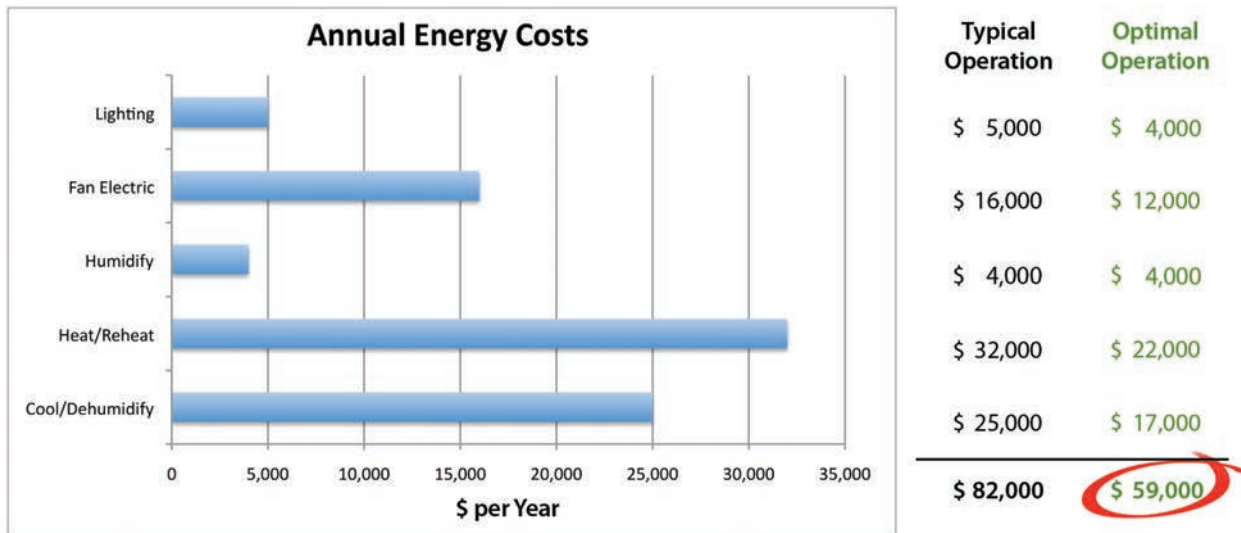

The Annual Energy Costs figure on p.77 shows the potential energy cost reduction that could result from such a careful examination. The “typical operation” annual cost is based upon the actual measured performance of an example storage area mechanical system. The “optimal operation” annual cost shows the savings that would result from eliminating unnecessary energy use. Based on analysis of collected data, the preservation quality of the storage climate would be unaffected by the change from typical to optimal, while the annual energy cost would be reduced by 28%.

In institutions with multiple mechanical systems there are many energy-saving opportunities and strategies. Some require engineering expertise and capital improvements, however, there are usually significant opportunities that can be identified by existing staff and which require little or no capital investment. These operational savings can be realized by looking for and correcting “sub-optimal operation.”

## 9C Operational Energy Saving Opportunities to be Investigated

Experience with monitoring the ways storage area mechanical systems actually operate and the findings indicated in the paragraphs above suggest that research by members of the Environmental Management Team in the following two areas may identify significant energy savings opportunities.

### Quantity of Outside Air

As you read in Section 9B, the amount of humidifying, reheating, cooling, and sub-cooling are all largely affected by the amount of outside air allowed to enter the system. The quantity of outside air entering most systems is fixed and does not change with occupancy or season of the year.

The quantity of outside air is based on assumptions about how many people will occupy the space, and how much outside air is required per person. Consideration is also given to the possibility that the materials stored may give off contaminants, the concentration of which will be diluted to acceptable levels by a continuous flow of outside air.

Because the energy cost incurred in conditioning the outside air is considerable and rising, it is appropriate to investigate the assumptions behind the need for outside air to determine if reductions are possible all of the time, during unoccupied periods, and/or seasonally. Define whether your space is “occupied” or “unoccupied” by code, and only bring in the minimum amount of outside air necessary. For many environments, for both preservation and sustainability, less is better. Systems with updated direct digital controls may be able to program the opening and closing of outside air dampers for occupied and unoccupied hours.

Any time outside air is restricted from the system the amount of work that the system has to perform is reduced. If the system is equipped with a variable speed drive, experiment to see how far the fan speed can be reduced (thereby moving air through the system more slowly) while still maintaining the desired environmental conditions.

### System Time of Operation

Years of monitoring mechanical system operation and storage climates have resulted in data recorded during periods of system failures and both intended and unintended system shutdown for various

durations. These observations demonstrated that some storage climates are unaffected by short-term system shutdowns and suggest that some systems could be shut off for certain portions of the day (unoccupied hours) for some portion of the year without reducing preservation quality.

Determining factors include the amount of exposure the storage spaces have to weather (quantity of exterior walls or roof), the construction of the storage space envelope, control of lighting in the storage spaces, and the configuration and control of the HVAC system.

IPI and Herzog/Wheeler & Associates are engaged in a four-year project to conduct controlled experiments in five research libraries located around the U.S. to document the potential for reducing energy consumption without compromising storage climate through the periodic shutdown of storage area HVAC systems. Funded by IMLS, this project will conclude in November 2013. IPI is also conducting research funded by NEH on the effect of temperature and humidity set backs on collection preservation and energy use. This project concludes in April 2013.

## Case Studies

IPI is working with an Environmental Management Team at each of the five research libraries involved in the IMLS-funded Energy Saving Opportunities project mentioned above. Team members selected the most appropriate candidate spaces, identified the proper channels to work through to make adjustments to mechanical system controls, and finalized the work plan for data gathering and analysis. It was determined that each institution would experiment with seven to ten hours of total shutdown time for each 24-hour period, generally conducted overnight. The time selected provided the greatest potential for energy savings, and the nighttime hours lessened the possibility of human comfort concerns. In addition, shutdowns during typically



cooler evening and night hours would lessen potential swings in environmental conditions. One institution chose to experiment with scheduling four hours of the shutdown during the middle of the day to take advantage of energy savings potential during peak electrical rate periods. Data from one-month shutdown test periods were reviewed before the full 12+ month experimental period began.

Early results show less than 33°F in temperature fluctuation during the average nightly shutdown, with no cumulative gain in temperature over time. The shutdown period is having little to no impact on the preservation quality of the space, and energy is being saved during each shutdown period. Relative humidity fluctuation during the shutdown period is minimal, with fluctuations of 2% to 5% observed. Data indicates that the systems recover their set point, or at least return to the condition they were previously providing, when they turn back on. Due to the rate of moisture equilibration for most collection materials this small amount of relative humidity change in the air should have little effect on the overall preservation quality of the environment.

Based on observations to date, carefully managed shutdowns of mechanical systems that serve collection storage areas have potential benefits for both preservation and energy savings. For most systems these savings come from reduced electrical consumption at fans or electrical heating, water consumption at the cooling coil, and steam or hot water at the heating coil.

A publication and associated web-resource focused on the optimal management of temporary HVAC shutdowns will be available at the close of this project.

A similar energy saving research project that IPI is conducting with a major library has focused on a storage facility with two large air handling units, one for the north and one for the south end of the building. The large book storage area selected for the shutdown experiment is surrounded by tempered space, has no added sources of heat or moisture, and is unoccupied at night. The project team chose to shut down one AHU for eight hours every night, seven days a week (1/3 of the normal AHU operation).

The effect of the shut down on collections was measured using IPI's Preservation Metrics™. Energy usage was measured based on:

- Measured air volumes that are moved, heated and cooled
- Measured fan amps
- Calculated BTUs of heating and cooling, related to dollar costs provided by the facility administrators

Based on these calculations the annual energy saving potential of a nightly shutdown of one or both AHUs serving the space was significant:

Constant Operation	One Unit	X 2 = Two Units
Cooling Costs	\$110,000	\$220,000
Heating Costs	\$98,000	\$196,000
Fan Operation Costs	\$25,650	\$51,300
TOTAL ANNUAL COST	\$233,650	\$467,300
One-third savings based on nightly shutdown	\$77,883	\$155,766

During the period of this experiment environmental data from the storage space showed no changes in relative humidity, and a maximum temperature increase of 2°F, summer or winter. We concluded that the risk-managed shutdowns had little or no effect on the preservation quality of the storage space, and that further tweaking could result in better environments and larger annual savings.

Keep in mind that these are risk-managed experiments in locations specifically selected for this research project. Any operational change in the mechanical system must be balanced by the maintenance of an acceptable environment for preservation.

# SECTION 4: ADDITIONAL INFORMATION

## GUIDE YOUR INSTITUTION TOWARD SUSTAINABLE PRESERVATION PRACTICES

### Section Four includes:

- Annotated Bibliography
- Influence of Local Climate on HVAC System Exercise with Regional Examples
- HVAC System Documentation Worksheet
- Funding Opportunities
- IPI's Environmental Management Products

## Annotated Bibliography

### Essentials: Current Research and Current Thinking

#### PUBLICATIONS

Erhardt, David and Marion Mecklenburg. "Relative Humidity Re-Examined." *Preventive Conservation: Practice, Theory, and Research*. Preprints of the Contributions to the Ottawa Congress. London: The International Institute for Conservation of Historic and Artistic Works (IIC), 1994, pp. 32-38.

A presentation of materials research that outlines the effects of relative humidity on certain materials and modes of decay, suggesting that many museum artifacts can safely withstand wider fluctuations in relative humidity than were previously accepted. The authors conclude that there is no one 'ideal' relative humidity for museum collections but suggests the ranges of relative humidity that minimize specific types of change in certain materials and objects. This paper was one of the first publications to call for the re-evaluation of relative humidity standards and ultimately initiated the discussion of appropriate RH guidelines that continues within the field.

Erhardt, D, Tumosa, C and Mecklenburg, M. "Applying Science to the Question of Museum Climate." *Museum Microclimates: Contributions to the Conference in Copenhagen, 19-23 November 2007*. Copenhagen: National Museum of Denmark, 2007, pp. 11-18. <http://www.natmus.dk/sw53828.asp>

A more recent discussion of the authors' materials research which lead to their conclusion that variations within the range of 30%RH to 60%RH are mechanically safe for general collections. The authors contextualize their recommendations by presenting a history of the development of previously accepted climate standards and delineate how their research can provide the basis for determination of allowable limits of variation in the environment. By distinguishing between material response and permanent or irreversible change (damage), the authors argue that permanence can be optimized by choosing a range of conditions that minimize long-term processes of decay and are also feasible and economical to maintain.

Reilly, J, Nishimura, D, and Zinn, E. "New Tools for Preservation: Assessing Long-term Environmental Effects on Library and Archives Collections". Washington, DC: Commission on Preservation and Access, 1995.

The 1995 publication by the Commission on Preservation and Access which introduced IPI's predictive models of deterioration, the Preservation Index (PI) and the Time-Weighted Preservation Index (TWPI), and IPI's temperature and humidity datalogger, the Preservation Environment Monitor (PEM), as new management tools for libraries, archives and museums. The technical basis for the Preservation Index and the calculation of the Time-Weighted Preservation Index are explained in detail. Methodology for using the TWPI to assess the preservation quality of environmental conditions is discussed with a sample case study, outlining how to interpret and apply TWPI values in data analysis.

Sebera, Donald K. *Isoperms: An Environmental Management Tool*. Washington, DC: Commission on Preservation and Access, 1994.

In this 1994 publication, author Donald Sebera provides an overview and practical explanation of his "isoperm method," an approach to quantify the combined effects of temperature and relative humidity upon the deterioration rate of paper-based collections. The author explains why the isoperm represents graphically a "line of constant permanence," where each combination of temperature and relative humidity conditions on the line have equivalent permanence values or effect on the collections. Methodology for reading isoperm graphs and the application of isoperm values as a strategy to evaluate the preservation consequences of different environmental parameters is presented.

## CONFERENCE PROCEEDINGS

*Gray Areas to Green Areas: Developing Sustainable Practices in Preservation Environments*, University of Texas, Kilgarlin Center for Preservation of the Cultural Record. Austin, Texas. November 1-2, 2007. <http://www.ischool.utexas.edu/kilgarlin/gaga/proceedings.html>

A symposium held at the University of Texas, Austin, which addressed the question of how to balance preservation concerns with sustainable practices, examining where the priorities of cultural stewardship may overlap or conflict with new practices for engineering and green building design, energy efficiency and energy reduction, and the responsibility of institutions to minimize their carbon footprints.

*Conference on Preventive Conservation: Museum Microclimates*, National Museum of Denmark and ICOM-CC Preservation Working Group. Copenhagen, Denmark. November 19-23, 2007. <http://www.natmus.dk/sw53828.asp>

An international conference organized by the National Museum of Denmark and the ICOM-CC Preventive Conservation Working Group which brought presenters from all over the world to discuss the current understanding of the effect the environment on collection materials and several alternative, innovative strategies for managing collection environments.

## BACKGROUND / HISTORICAL SOURCES

Plenderleith, H.J and P. Philippot. "Climatology and Conservation in Museums." *Museum*, 13.4 (1960) : pp. 243-289.

<http://www.bcin.ca/Interface/openbcin.cgi?submit=submit&Chinkey=30266> (abstract)

Thomson, Garry. *The Museum Environment*. Butterworths, London, 1978

This book, first published in 1978, is the grandfather of museum environment recommendations. A number of papers related to environmental conservation predated it but none had the same level of influence or lasting impact as this book. In the second edition, indoor RH recommendations fall into four categories, depending on the outdoor climate and the materials being stored. RH "day and night throughout the year" is recommended to be  $50 \pm 5\%RH$  or  $55 \pm 5\%RH$  with the note that, "the level may be fixed higher or lower, but for mixed collections should be in the range "45 - 60%". Temperature recommendations are  $19^{\circ}C \pm 1^{\circ}C$  in winter and up to  $24^{\circ}C \pm 1^{\circ}C$  during the summer, and keeping temperature constant is encouraged to minimize RH cycling.



## Material Response and Behavior

Bigourdan, Jean-Louis, Peter Z. Adelstein, and James M. Reilly, "Moisture and Temperature Equilibration: Behavior and Practical Significance in Photographic Film Preservation," *La Conservation: Une Science en Evolution, Bilans et Perspectives, Actes des Troisiemes Journées Internationales d'Etudes de l'ARSAG*, Paris, 21 au 25 Avril 1997, (Paris: Association pour la recherche scientifique sur les arts graphiques, 1997) pp. 154-164. [https://www.imagepermanenceinstitute.org/webfm\\_send/298](https://www.imagepermanenceinstitute.org/webfm_send/298)

A tutorial paper that uses research data to explain how certain enclosure types can slow the rate of moisture equilibration but no enclosures significantly affect the rate of temperature equilibration. Observations of the behavior of hygroscopic materials within a microclimate are also discussed, supporting the authors' conclusion that tight enclosures mitigate the humidity fluctuations and the current recommended range of RH fluctuations may therefore be unnecessarily narrow.

Bigourdan, Jean-Louis, and James M. Reilly. "Effects of Fluctuating Environments on Paper Materials-Stability and Practical Significance for Preservation" 2003. <http://www.imagepermanenceinstitute.org/resources/papers-articles-reports>

The final grant report for a project funded by the National Endowment for the Humanities (NEH) and the Institute of Museum and Library Services (IMLS) that investigated three primary topics: (1) the effect of cycling environments on the chemical stability of paper and film, (2) the rate of moisture conditioning for a variety of materials and enclosures, and (3) the impact of cycling conditions on the microenvironment and moisture content of archival materials.

Child, Robert E. "Insect Damage as a Function of Climate." *Museum Microclimates: Contributions to the Conference in Copenhagen, 19-23 November 2007*. Copenhagen: National Museum of Denmark, 2007, pp. 57-60.

A description of the effect of environmental conditions on insect activity, including a brief explanation of why activity is increased by higher ambient temperature and relative humidity.

Erhardt, David and Marion Mecklenburg. "Relative Humidity Re-Examined." *Preventive Conservation: Practice, Theory, and Research. Preprints of the Contributions to the Ottawa Congress*. London: The International Institute for Conservation of Historic and Artistic Works (IIC), 1994, pp. 32-38.

A presentation of materials research that outlines the effects of relative humidity on certain materials and modes of decay, suggesting that many museum artifacts can safely withstand wider fluctuations in relative humidity than were previously accepted.

Price, Lois Olcott. *Managing a Mold Invasion: Guidelines for Disaster Response*. Conservation Center for Art and Historic Artifacts: Philadelphia, 1994.

A brief pamphlet on how to identify mold, respond to a mold break out and eventually plan to prevent further mold incidents by controlling the relative humidity.

Smith, Kristin M. "Drawing the Line on Acceptable Relative Humidity Fluctuations: Understanding the Moisture Buffering Capacity of Enclosures". *Climate Notes*. Issue 14: December, 2011. <https://www.imagepermanenceinstitute.org/resources/newsletter-archive/v14/acceptable-humidity-fluctuations>

A discussion of the significance of temperature and relative humidity fluctuations, with a focus on the moisture-buffering effect of enclosures. Results from IPI research demonstrating that certain enclosures can slow the rate of moisture equilibration are presented and used to support the conclusion that long-term humidity extremes are more significant than short-term fluctuations.

## Defining Temperature and Relative Humidity Conditions: Standards and Environmental Parameters

Ashley-Smith, Jonathan, Nick Umney and David Ford. "Let's Be Honest-Realistic Environmental Parameters for Loaned Objects." *Preventive Conservation: Practice, Theory, and Research. Preprints of the Contributions to the Ottawa Congress*. London: The International Institute for Conservation of Historic and Artistic Works (IIC), 1994, pp. 28-31.

A frank plea for more logical and transparent discussions about environmental requirements in institutional loan agreements. Citing several anonymous anecdotes, the author reveals the need for a new approach to negotiating environmental conditions for borrowed-objects and suggests that a little more understanding and honesty could lead to a less restrictive attitude without increasing risk to the collections.

Conrad, Ernest A. "The Realistic Preservation Environment," *Alternative Archival Facilities*. National Archive and Records Administration's 14th Annual Preservation Conference, Washington, DC. 25 March 1999. <http://www.archives.gov/preservation/storage/realistic-preservation-environment.html>

A concise description of how to evaluate a buildings' capacity for climate control and identify sources of heat and moisture, in order to arrive at a cost-conscious design for climate control.

Erhardt, David and Marion Mecklenburg. "Relative Humidity Re-Examined." *Preventive Conservation: Practice, Theory, and Research. Preprints of the Contributions to the Ottawa Congress*. London: The International Institute for Conservation of Historic and Artistic Works (IIC), 1994, pp. 32-38.

A presentation of materials research that outlines the effects of relative humidity on certain

materials and modes of decay, suggesting that many museum artifacts can safely withstand wider fluctuations in relative humidity than were previously accepted.

Erhardt, D, Mecklenburg, M., Tumosa, C. and McCormick-Goodhard, M. "The Determination of Allowable RH Fluctuations." *Newsletter: Western Association for Art Conservation*. Vol 17, Number 1 (Jan 1995): p. 19. <http://cool.conservation-us.org/waac/wn/wn17/wn17-1/wn17-108.html>

A more detailed explanation of the authors' research on the mechanism of damage caused by RH fluctuations, including data from stress-strain curves, moisture absorption isotherms and plots of RH values which produce "yielding" (response without irreversible deformation) or "failure" (irreversible deformation of the material).

Erhardt, D., Tumosa, C. and Mecklenburg, M. "Applying Science to the Question of Museum Climate." *The Effect of Environment on Artifacts. Contribution to Museum Microclimates, Conference on Preventive Conservation, National Museum of Denmark, 19 November 2007.* <http://www.natmus.dk/sw53828.asp>

A more recent discussion of the authors' materials research which lead to their conclusion that variations within the range of 30%RH to 60%RH are mechanically safe for general collections.

Hatchfield, Pamela. "Crack Warp Shrink Flake: A New Look at Conservation Standards." *Museum: American Association of Museums (AAM)*, January-February, 2011.

A succinct review of the evolution of environmental standards and an outline of the current re-evaluation of temperature and humidity recommendations for museums. The interim guidelines from AIC's Environmental Guidelines Working Group – a committee called to discuss the broadening of environmental parameters for collections – are also presented.

Kerschner, Richard L. "A Practical Approach to Environmental Requirements for Collections in Historical Buildings." *Journal of the American Institute for Conservation*. Vol 34, Issue 1, Article 8 (1992): pp 65 to 76. <http://www.jstor.org/stable/3179613?seq=1>

An outline of seven practical climate control actions to guide environmental management decisions in historic structures.

Michalski, Stefan. "The Ideal Climate, Risk Management, the ASHRAE Chapter, Proofed Fluctuations, and Toward a Full Risk Analysis Model," *Contribution to the Experts' Roundtable on Sustainable Climate Management Strategies, Tenerife, Spain, April 2007.* [http://www.getty.edu/conservation/science/climate/paper\\_michalski.pdf](http://www.getty.edu/conservation/science/climate/paper_michalski.pdf)

A transcript from the author's Roundtable contribution where he discussed the new ASHRAE chapter, the logic of classifying levels of climate control and identifying the associated collection risk

levels, and the movement towards a risk analysis model that incorporates his concept of “proofed” RH fluctuations.

Michalski, Stefan and David Grattan. “Environmental Guidelines for Museums.” *Conservation Resource Center* (web), Canadian Conservation Institute. 2010. <http://www.cci-icc.gc.ca/crc/articles/enviro/index-eng.aspx>

A general introduction to the control of ambient temperature and relative humidity in museums, based on the “Museums, Galleries, Archives and Libraries” chapter in the *American Society of Heating, Refrigeration, and Air Conditioning Engineers Inc. (ASHRAE) Handbook*, which classifies the amount of climate control and links the resulting range of RH fluctuation to predicted risk to collection materials.

“Museums, Galleries, Archives and Libraries”. *Heating, Ventilating, and Air-Conditioning Applications, 2007 ASHRAE Handbook*. American Society of Heating, Refrigerating and Air-Conditioning Engineers, Inc., 2007. Chapter 21, pp.21.1 – 21.23. [http://www.knovel.com/web/portal/basic\\_search/display?\\_EXT\\_KNOVEL\\_DISPLAY\\_bookid=2397](http://www.knovel.com/web/portal/basic_search/display?_EXT_KNOVEL_DISPLAY_bookid=2397)

A reference for architects and building engineers that describes HVAC system design parameters and performance target specifications for cultural heritage institutions, according to the building's classification and possible level of climate control.

Ryhl-Svendsen, M., Jensen, L., Larsen, P. and Padfield, T. “Does a Standard Temperature Need to be Constant?” Contribution to the Going Green conference at the British Museum, 24 April 2009. <http://www.conservationphysics.org/standards/standardtemperature.php>

A comparison of data from three buildings which used air-conditioning, conservation heating or dehumidification without temperature control as methods to control RH, resulting the author's observation that using only dehumidification offered the greatest energy-savings and best overall climate for the collections.

Padfield, Tim. “The Role of Standards and Guidelines: Are They a Substitute for Understanding a Problem or a Protection Against the Consequences of Ignorance?” *Durability and Change*, Krumbein, W. E. et al (editors). Wiley 1994, pp191-99. <http://www.padfield.org/tim/cfys/ppubs/dahlem.pdf>

An argument against applying fixed environmental standards without questioning the relevance to the specific situation; the author encourages the development of rational and flexible guidelines in order to accommodate a greater variety of historic structures and materials.

## Documenting the Current Storage Environment

Arenstein, Rachel. "Comparing Temperature and Relative Humidity Dataloggers for Museum Monitoring". *Conserve O Gram*, September 2011, Number 3/3.

A concise overview of features to consider when researching temperature and relative humidity dataloggers, including a table comparing the specifications of the ten common devices.

Smith, Kristin M. "He Said, She Said: Discrepancies in Temperature and Relative Humidity Readings". *Climate Notes*. Issue 5: September, 2009. <https://www.imagepermanenceinstitute.org/resources/newsletter-archive/v5/discrepancies-readings>

An article from IPI's newsletter explaining why discrepancies between temperature and humidity readings are inherent to nature of measurement and rarely indicate malfunction of the device.

## Energy Saving Options and Alternative Environmental Management Strategies

Brokerhof, Agnes W. "Applying the Outcome of Climate Research in Collection Risk Management." *Museum Microclimates: Contributions to the Conference in Copenhagen, 19-23 November 2007*. Copenhagen: National Museum of Denmark, 2007, pp. 115-122. <http://www.natmus.dk/sw53828.asp>

A discussion of the focus and application of research on the deterioration of materials within the conservation field. The author argues there is a need for the field to transition from defining numerical standards to a systematic approach of collection risk management.

Henry, Michael C. "The Heritage Building Envelope as a Passive and Active Climate." *Opportunities and Issues in Reducing Dependency on Air-Conditioning*, Contribution to Experts' Roundtable on Sustainable Climate Management Strategies, April 2007. [http://www.getty.edu/conservation/our\\_projects/science/climate/paper\\_henry.pdf](http://www.getty.edu/conservation/our_projects/science/climate/paper_henry.pdf)

A commentary on environmental management strategies that utilize the building's features to moderate its conditions rather than air-conditioning, with several case studies to demonstrate the implementation and possible risks. Cultural and global significance of reducing energy consumption is also discussed.

Padfield, Tim and Poul Larsen. "Low-Energy Air Conditioning of Archives." *Preprints, 14th Triennial Meeting, The Hague, 12-15 September 2005: ICOM Committee for Conservation*. London: James & James (Science Publishers) Ltd, 2005, pp. 677-80. [http://www.conservationphysics.org/arnemag/arnemag\\_nrwch.pdf](http://www.conservationphysics.org/arnemag/arnemag_nrwch.pdf)

A discussion of purpose-built storage buildings designed for passive climate control, with data from two specific buildings in Denmark.

## Significance of Sustainable Preservation Practices

Henry, Michael C. "What Will the Cultural Record Say About Us? Stewardship of Culture and the Mandate for Environmental Sustainability." Keynote speech at Gray Areas to Green Areas Conference on Developing Sustainable Preservation Environments, 1 November 2007. <http://www.ischool.utexas.edu/kilgarlin/gaga/proceedings2008/GAGA07-henry.pdf>

A brief discussion of why it is imperative for cultural heritage institutions to consider their role in environmental sustainability and global climate change, concluding with a succinct outline of a framework for sustainable environmental management.

Henry, Michael C. "From the Outside In: Preventive Conservation, Sustainability and Environmental Management," *Conservation: The Getty Conservation Institute Newsletter*: V22, No. 1: Spring 2007. <http://www.getty.edu/conservation/publications/newsletters/pdf/v22n1.pdf>

An article encouraging stewards of cultural heritage to review current approaches to preventive conservation and to seek new environmental management strategies that promote not only the conservation of material culture but also conservation of the global environment.

Henry, Michael C. "To Everything There is a Season: Strategic Thinking for Sustainable Environmental Management for Collections Conservation." *Combined Actions and Coordinated Efforts in Pursuit of Sustainable Preservation*. Contribution to the Sustainable Cultural Heritage Conference, Washington, DC, 11 May 2009. [http://www.neh.gov/projects/Conference\\_09May/NEH-CNR\\_Conference.htm](http://www.neh.gov/projects/Conference_09May/NEH-CNR_Conference.htm)

A conference presentation that offers a definition of 'sustainability' as it relates to cultural heritage institutions and lists several recommendations for developing strategic and sustainable environmental management practices, in lieu of the traditional, prescriptive model.

Kino, Carol, "Keeping Art, and Climate, Controlled," *New York Times*, April 2009. <http://www.nytimes.com/2009/04/05/arts/design/05kino.html?pagewanted=all>

The 2009 flood at Craggside, a Victorian House Museum in Northumberland, England, serves as a starting point for this discussion of how climate control fits within the priorities for a museum collection and highlights the key points of the contemporary research in environmental management.

Podany, Jerry. "Sustainable Stewardship: Preventive Conservation in a Changing World," *Cultural Heritage and Climate Change*. Contribution to the Sustainable Cultural Heritage Conference, Washington, DC, 11 May 2009. [http://www.neh.gov/projects/Conference\\_09May/PODANY\\_09May.pdf](http://www.neh.gov/projects/Conference_09May/PODANY_09May.pdf)

A discussion of how the preventive conservation field has evolved over the last few decades, giving perspective to the expanding roles and responsibilities of the profession resulting from progress in research and the growing concern for sustainable practices.

Staniforth, Sarah. "Sustainability and Collections," *Conservation Perspectives: The GCI Newsletter: V26. 1: Spring 2011*. [http://www.getty.edu/conservation/publications\\_resources/newsletters/26\\_1/sustainability.html](http://www.getty.edu/conservation/publications_resources/newsletters/26_1/sustainability.html)

A brief article about the role of sustainability in museums, including options for achieving energy reduction targets, the evolution of environmental guidelines for collection materials, and adapting museum buildings to meet global climate changes.

## Historical Houses and Small Collections

Henry, Michael C. "The Heritage Building Envelope as a Passive and Active Climate: Opportunities and Issues in Reducing Dependency on Air-Conditioning." Contribution to Experts' Roundtable on Sustainable Climate Management Strategies, April 2007. [http://www.getty.edu/conservation/our\\_projects/science/climate/paper\\_henry.pdf](http://www.getty.edu/conservation/our_projects/science/climate/paper_henry.pdf)

A commentary on environmental management strategies that utilize the building's features to moderate its conditions rather than air-conditioning, with several case studies to demonstrate the implementation and possible risks. Cultural and global significance of reducing energy consumption is also discussed.

Kerschner, Richard L. "A Practical Approach to Environmental Requirements for Collections in Historical Buildings." *Journal of the American Institute for Conservation*, Vol 34, Issue 1, Article 8 (1992): pp 65 to 76. <http://www.jstor.org/stable/3179613?seq=1>

The author, Director of the Shelburne Museum, outlines seven practical climate control actions to guide environmental management decisions in historic structures.

Kerschner, Richard L and Jennifer Baker. *Practical Climate Control: A Selected, Annotated Bibliography*. 2008. <http://cool.conservation-us.org/byauth/kerschner/ccbiblio.html>

An online, annotated bibliography with resources specifically focused on environmental management strategies in historic structures.

Kerschner, Richard L. "Providing Safe and Practical Environments for Cultural Properties in Historic Buildings...and Beyond," Contribution to 20th Annual Archives Preservation Conference, *Beyond the Numbers: Specifying and Achieving an Efficient Preservation Environment*. 16 March 2006. <http://www.archives.gov/preservation/conferences/2006/kerschner.pdf>

A discussion of how the Shelburne Museum has approached creating and maintaining efficient storage environments over the last three decades; the author describes the challenges, surprises and successes with alternative solutions and unconventional systems for the Shelburne's various building types and collection materials.

Maekawa, S. and Vincent Beltran. "Climate Controls for Historic Buildings: A New Strategy," *Conservation Perspectives: The GCI Newsletter*: VI 9.1: Spring 2004. [http://www.getty.edu/conservation/publications\\_resources/newsletters/19\\_1/news\\_in\\_cons2.html](http://www.getty.edu/conservation/publications_resources/newsletters/19_1/news_in_cons2.html)

A description of several case studies on alternative climate control strategies, particularly for historic buildings in hot and humid climates, using heating and ventilation to lower relative humidity.

## Online Resources: Conference Proceedings and Roundtable Discussions

*Experts' Roundtable on Sustainable Climate Management Strategies*, Getty Conservation Institute. Tenerife, Spain. April, 2007.

[http://www.getty.edu/conservation/our\\_projects/science/climate/climate\\_experts\\_roundtable.html#proceedings](http://www.getty.edu/conservation/our_projects/science/climate/climate_experts_roundtable.html#proceedings)

*Gray Areas to Green Areas: Developing Sustainable Practices in Preservation Environments*, University of Texas, Kilgarlin Center for Preservation of the Cultural Record. Austin, Texas. November 1-2, 2007.

<http://www.ischool.utexas.edu/kilgarlin/gaga/proceedings.html>

*Conference on Preventive Conservation: Museum Microclimates*, National Museum of Denmark and ICOM-CC Preservation Working Group. Copenhagen, Denmark. November 19-23, 2007.

<http://www.natmus.dk/sw53828.asp>

*Reviewing Environmental Conditions: NMDC Guiding Principles for Reducing Museums' Carbon Footprint*. National Museum Directors' Conference. May, 2008.

<http://www.nationalmuseums.org.uk/what-we-do/contributing-sector/environmental-conditions/>



*Climate Change and Museum Collections*, International Institute for Conservation of Historic and Artistic Works (IIC). London, England. September 18, 2008

[http://www.iiconservation.org/dialogues/IIC\\_climate\\_change\\_transcript.pdf](http://www.iiconservation.org/dialogues/IIC_climate_change_transcript.pdf)

*NMDC Response to the Museums Association Consultation: Sustainability and Museums*. National Museum Directors' Conference. September, 2008.

[http://www.nationalmuseums.org.uk/media/documents/publications/nmdc\\_response\\_ma\\_sustainability.pdf](http://www.nationalmuseums.org.uk/media/documents/publications/nmdc_response_ma_sustainability.pdf)

*Sustainable Cultural Heritage*, National Endowment for the Humanities (NEH) and Consiglio Nazionale delle Ricerche (CNR). Washington, DC. May 11, 2009.

[http://www.neh.gov/projects/Conference\\_09May/NEH-CNR\\_Conference.htm](http://www.neh.gov/projects/Conference_09May/NEH-CNR_Conference.htm)

*Rethinking the Museum Climate*, Museum of Fine Arts, Boston, and The Getty Conservation Institute. Boston, April 12-13, 2010.

<http://blog.conservation-us.org/blogpost.cfm?threadid=2227&catid=175>

*The Plus / Minus Dilemma: The Way Forward in Environmental Guidelines*. Dialogues for the New Century: Discussions on the conservation of cultural heritage in a changing world. International Institute for Conservation (IIC) and the American Institute for Conservation (AIC) of Historic and Artistic Works. Milwaukee, WI. May 13, 2010.

[http://www.iiconservation.org/dialogues/Plus\\_Minus\\_trans.pdf](http://www.iiconservation.org/dialogues/Plus_Minus_trans.pdf)

## Influence of Local Climate on HVAC System Exercise with Regional Examples

Reviewing your local climate data against the desired storage climate can quickly illustrate when and how often your mechanical system will need to provide heat, humidification, and dehumidification in order to provide a stable environment for collections.

This section includes examples from Atlanta GA, Austin TX, Los Angeles CA, New Haven CT, and St. Paul MN as illustrations. Reviewing temperature, relative humidity, and dew point graphs of your local climate throughout a typical year will help you understand the influence your local climate has on your storage environments.

## The Local Climate – Atlanta, Georgia Example

The following graphs show the 2011 annual temperature, relative humidity, and dew point for Atlanta GA. Atlanta has a humid, subtropical climate with hot, humid summers and mild winters that are occasionally cold by southeastern standards.

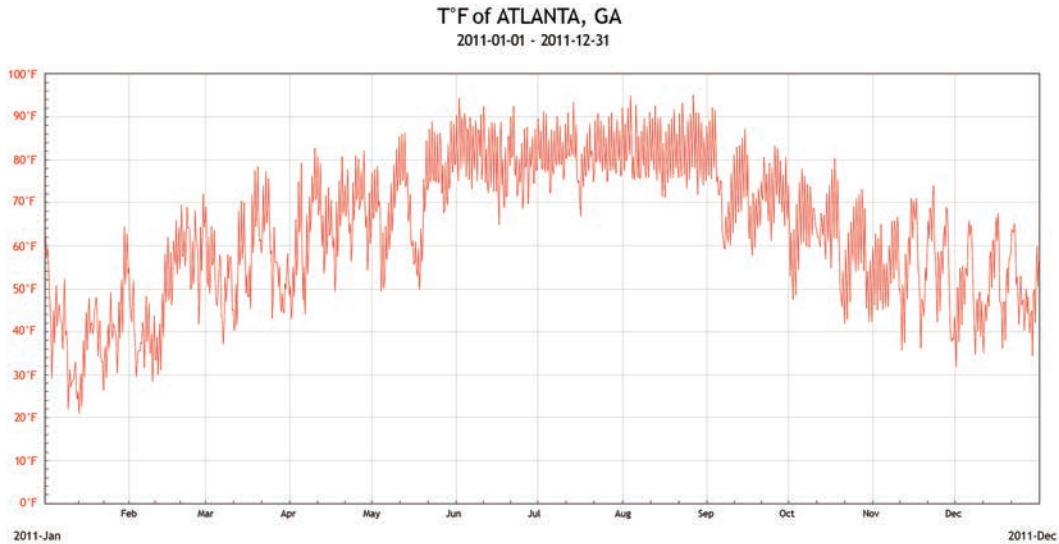

The temperature graph above shows that the outside air temperature is 70°F or lower about 55% of the time, and 70°F or higher about 45% of the time. In order to maintain a temperature of 70°F in a collection storage facility in this climate, you would need mechanical equipment capable of providing heat to the spaces from October through early May. A good thermal envelope could be needed to flatten out wide daily temperature swings.

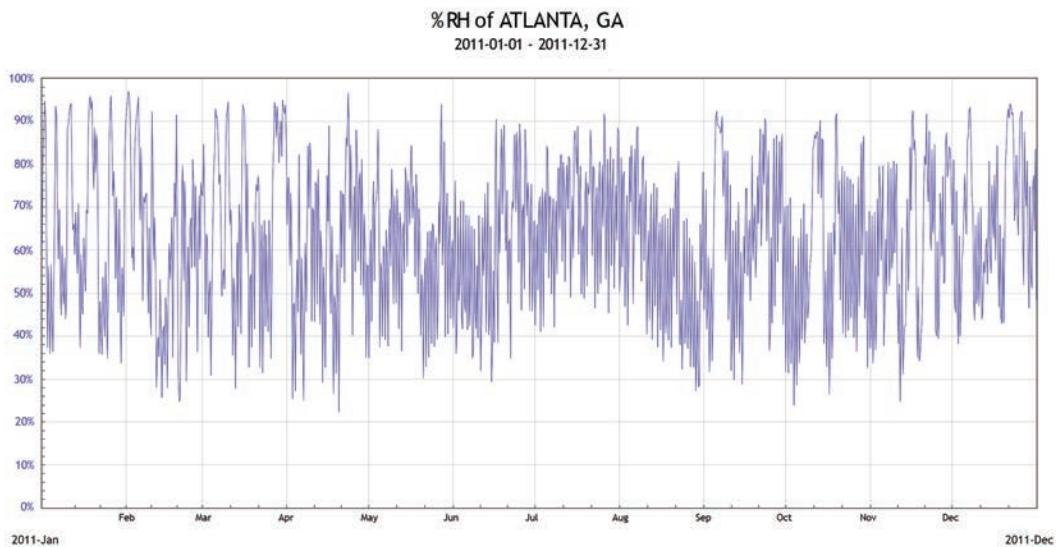

The outdoor relative humidity graph on the previous page shows wide daily swings in RH you round. This suggests that any outside air that enters the collection storage area will be too humid most of the time. While this graph is of some interest, it does not provide a clear idea of how much dehumidification will be required and when it is needed, as relative humidity alone does not indicate how much moisture is in the air. Relative humidity illustrates the ratio of how much moisture is present relative to how much moisture the air can hold at a given temperature. To judge how much you should dehumidify and when, you need to know how much moisture is actually present in the outside air (the absolute humidity of the outside air) versus the amount of moisture you want in the indoor air (the desired absolute humidity of the storage area).

The dew point temperature is an indirect expression of the absolute humidity in the air (see Section 5B, Understanding the Moisture Content of the Air, for more information). A comparison of the outside air dew point temperature and the desired storage area dew point temperature illustrates the need for humidification and dehumidification. For this example we used a 50°F dew point temperature.

The outside air dew point temperature of Atlanta GA seen in the graph below shows that the air outside is below the desired 50°F outside air dew point temperature a little over half of the year, generally from January to April, and again from October to December. Any outside air brought into the storage space during this time will need humidification. The dew point temperature is above 50°F from May to September generally, during which time dehumidification may be required.

Note that redefining the desired indoor conditions to 70°F and 35% RH (with the dew point temperature at 41°F) would somewhat reduce the need to humidify.

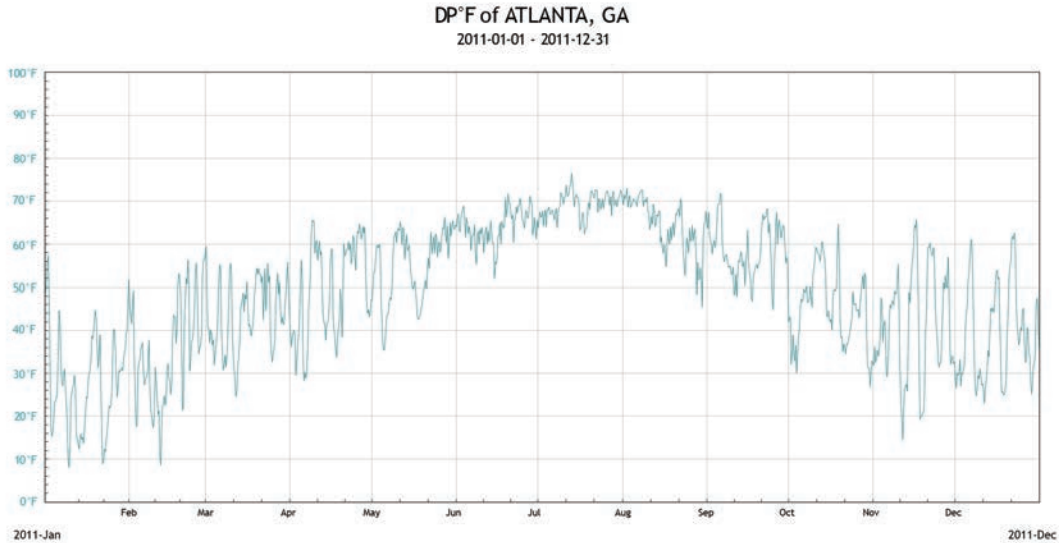

## The Local Climate – Austin, Texas Example

The following graphs show the 2011 annual temperature, relative humidity, and dew point for Austin TX. Austin has a humid subtropical climate with very hot, humid summers and mild, relatively dry winters.

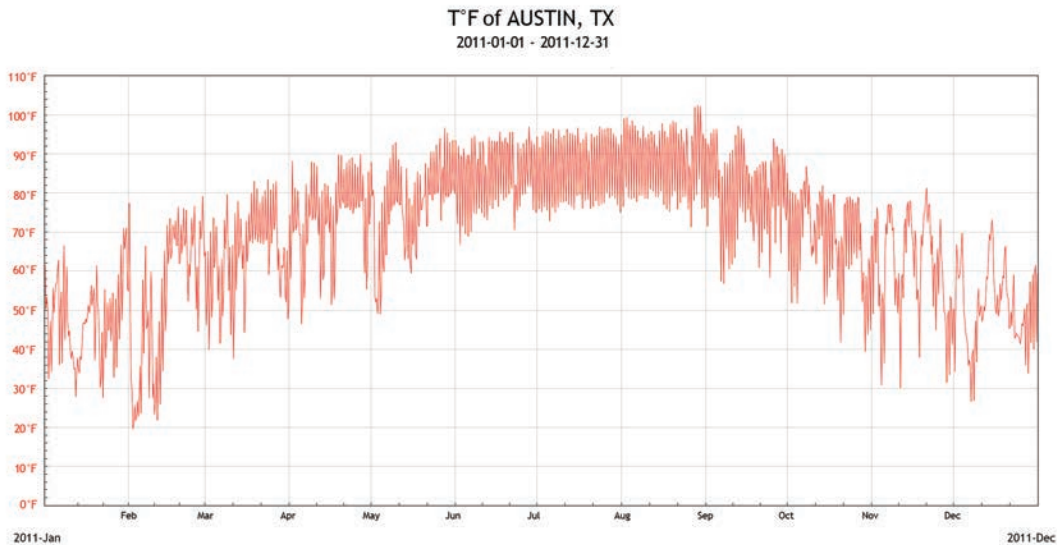

The temperature graph shows that the outside air temperature is 70°F or lower about 55% of the time and 70°F or above about 45% of the time. In order to maintain a temperature of 70°F in a collection storage facility in this climate, you would need mechanical equipment capable of providing heat to the spaces from January thru March and again in November and December. Cooling would be required most of June through September to maintain this temperature. A good thermal envelope could be needed to flatten out wide daily temperature swings.

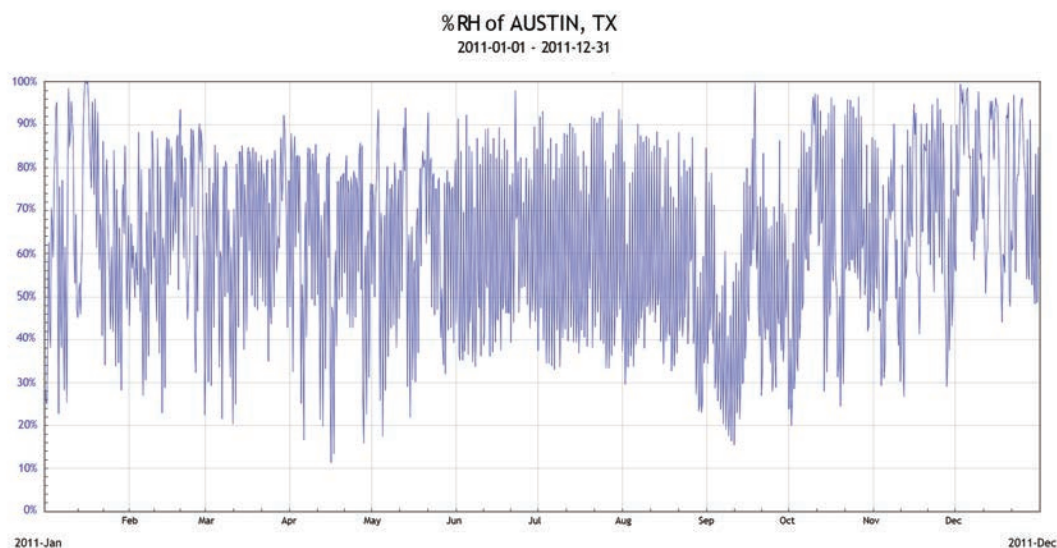

The outdoor relative humidity graph on the previous page shows wide daily swings in RH throughout the year. This suggests that any outside air that enters the collection storage area will be too humid most of the time. While this graph is of some interest, it does not provide a clear idea of how much dehumidification will be required and when it is needed, as relative humidity alone does not indicate how much moisture is in the air. Relative humidity illustrates the ratio of how much moisture is present relative to how much moisture the air can hold at that temperature. To judge how much and when you should dehumidify, you need to know how much moisture is actually present in the outside air (the absolute humidity of the outside air) versus the amount of moisture you want in the indoor air (the desired absolute humidity of the storage area).

The dew point temperature is an indirect expression of the absolute humidity of the air (see Section 5B, Understanding the Moisture Content of the Air, for more information). A comparison of the outside air dew point temperature and the desired storage area dew point temperature illustrates the need for humidification and dehumidification. For this example we used a 50°F dew point temperature.

The outside air dew point temperature of Austin TX seen in the graph below shows that the air outside is above the desired 50°F outside air dew point temperature about 65% of the time, particularly between April and September. Any outside air brought into the storage space during this time would need dehumidification. The dew point temperature is below 50°F about 35% of the time, generally between January and March, and again periodically from October through December. During this time air entering the storage space would require humidification.

Note that allowing the indoor conditions to move to 70°F and 35% RH (dew point temperature equaling 41°F) would somewhat reduce the need to humidify.

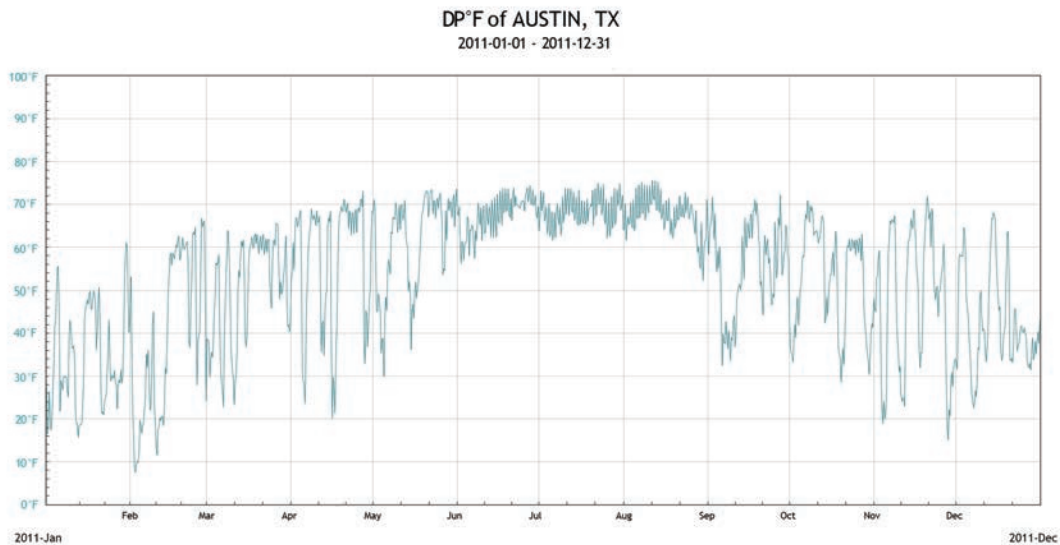

## The Local Climate – Los Angeles, CA Example

The following graphs show the 2011 annual temperature, relative humidity, and dew point for Los Angeles CA. Los Angeles has a Subtropical-Mediterranean climate with plenty of sun throughout the year and only 35 days with measureable precipitation in an average year. Daily temperature swings can be substantial, particularly inland where the difference between the average daily high and low can be 30°F or more.

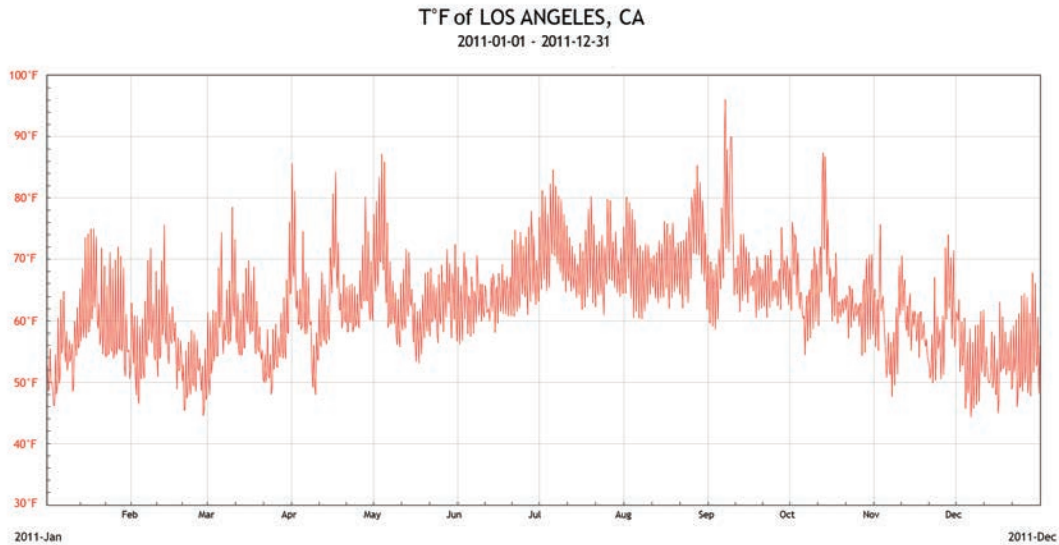

The temperature graph above shows that the outside air temperature is 70°F or lower about 80% of the time, and 70°F or higher about 20% of the time. In this case the regional temperature, which is generally stable and rarely very hot, is an asset to managing the storage climate for preservation. Maintaining an indoor temperature below 70°F would require minimal heating or cooling.

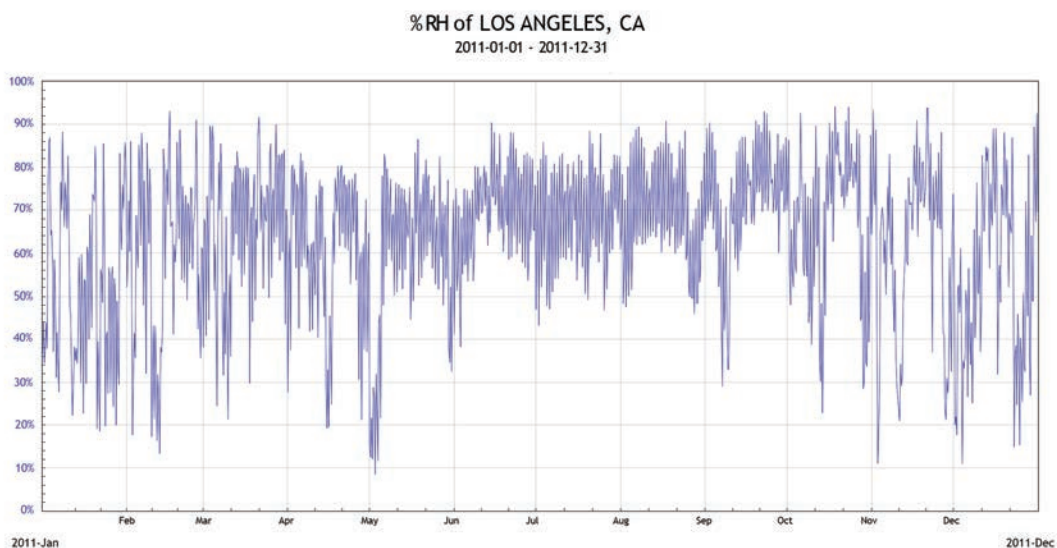

The outdoor relative humidity graph on the previous page shows wide daily swings in RH, particularly in the fall and winter months, and an RH above 60% much of the year. This suggests that any outside air that enters the collection storage area will be too humid most of the time. While this graph is of some interest, it does not provide a clear idea of how much dehumidification will be required and when it is needed, as relative humidity alone does not indicate how much moisture is in the air. Relative humidity illustrates the ratio of how much moisture is present relative to how much moisture the air can hold at a given temperature. To judge how much you should dehumidify and when, you need to know how much moisture is actually present in the outside air (the absolute humidity of the outside air) versus the amount of moisture you want in the indoor air (the desired absolute humidity of the storage area).

The dew point temperature is an indirect expression of the absolute humidity of the air (see Section 5B, Understanding the Moisture Content of the Air for more information). A comparison of the outside air dew point temperature and the desired storage area dew point temperature illustrates the need for humidification and dehumidification. For this example we used a 50°F dew point temperature.

The outside air dew point temperature of Los Angeles CA seen in the graph below shows that the air outside is below the desired 50°F dew point temperature about half of the year, generally from November to May. Outside air brought into the storage space during this time would need humidification. The dew point temperature is above 50°F between June and November, during which time dehumidification may be required.

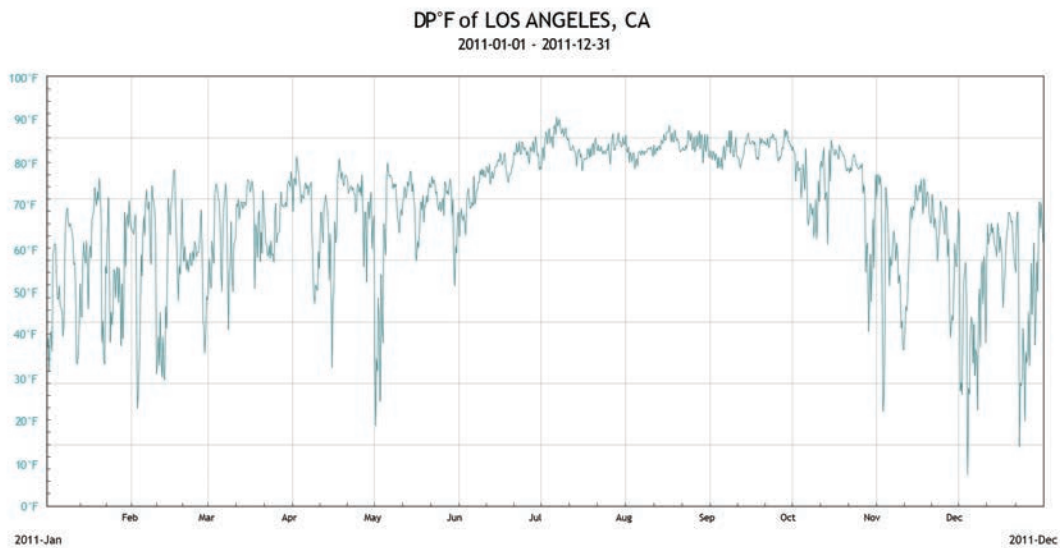

## The Local Climate – New Haven, Connecticut Example

The following graphs show the 2011 annual temperature, relative humidity, and dew point for New Haven CT. New Haven has a typical climate for New England and much of the northeastern US. Summers are warm to moderately hot, with high levels of humidity. Winters are cold and humid with frequent snowfalls.

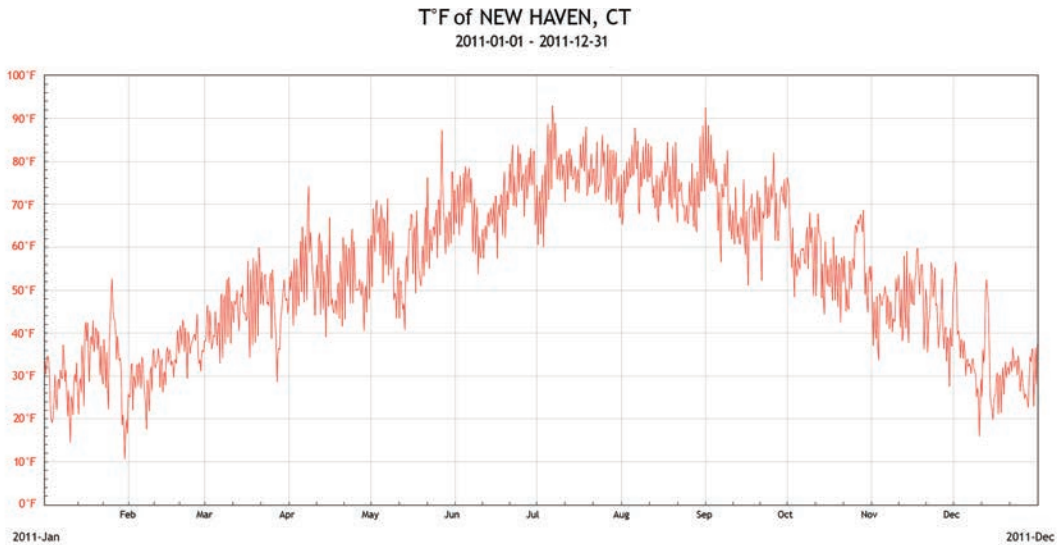

The temperature graph above shows that the outside temperature is 70°F or lower about 65% of the time, and 70°F or higher about 35% of the time. A collection storage facility in this climate would need mechanical equipment capable of providing heat to the spaces from late September through June to maintain an indoor temperature of 70°F. Cooling would be required frequently between late June and September. A good thermal envelope could be expected to flatten out wide daily temperature swings.

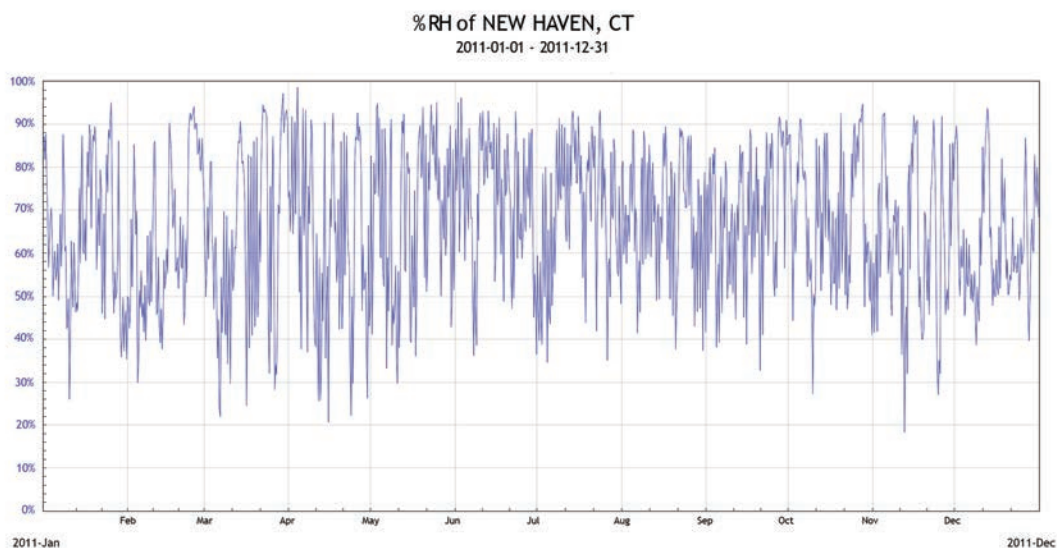



The outdoor relative humidity graph on the previous page shows wide daily swings in RH throughout the year. This suggests that any outside air that enters the collection storage area will be too humid most of the time. While this graph is of some interest, it does not provide a clear idea of how much dehumidification will be required and when it is needed, as relative humidity alone does not indicate how much moisture is in the air. Relative humidity illustrates the ratio of how much moisture is present relative to how much moisture the air can hold at a given temperature. To judge how much you should dehumidify and when, you need to know how much moisture is actually present in the outside air (the absolute humidity of the outside air) versus the amount of moisture you want in the indoor air (the desired absolute humidity of the storage area).

The dew point temperature is an indirect expression of the absolute humidity of the air (see Section 5B, Understanding the Moisture Content of the Air for more information). A comparison of the outside air dew point temperature and the desired storage area dew point temperature illustrates the need for humidification and dehumidification. For this example we used a 50°F dew point temperature.

The outside air dew point temperature of New Haven CT seen in the graph below shows that the air outside is below the desired 50°F dew point temperature about two thirds of the year, generally from January through mid-May and again from October through December. Outside air brought into the storage space during this time would need humidification. The dew point temperature is above 50°F from mid-May through September, during which time dehumidification may be required.

Note that redefining the desired indoor conditions to 70°F and 35% RH (with the dew point temperature at 41°F) would somewhat reduce the need to humidify.

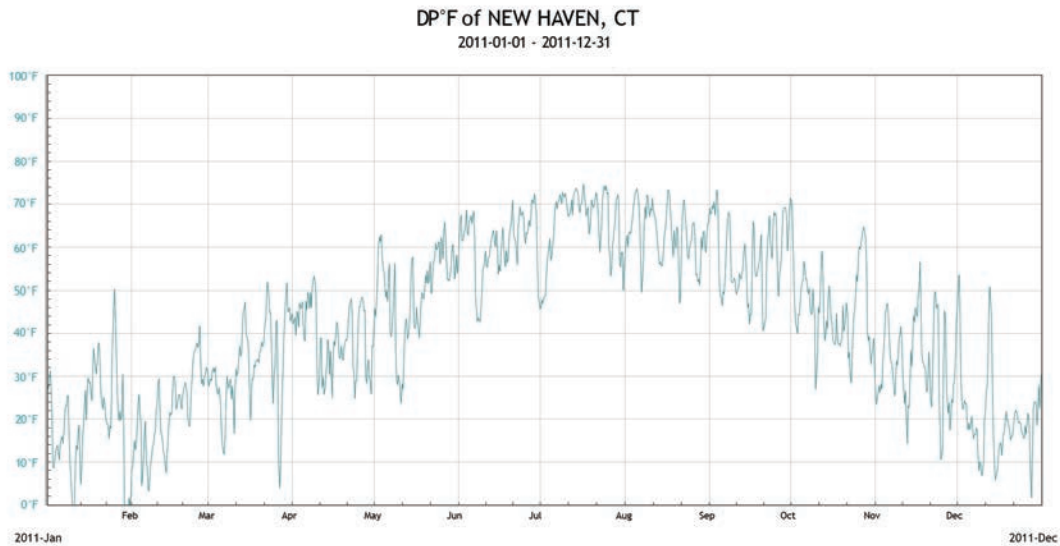

## The Local Climate – St. Paul, Minnesota Example

The following graphs show the 2011 annual temperature, relative humidity, and dew point for St. Paul MN. Far from the moderating effects of the Atlantic and Pacific Oceans, the Ohio Valley and High Plains regions of the Midwest experience large seasonal swings in temperature and humidity. Winter is very cold and summer is relatively warm.

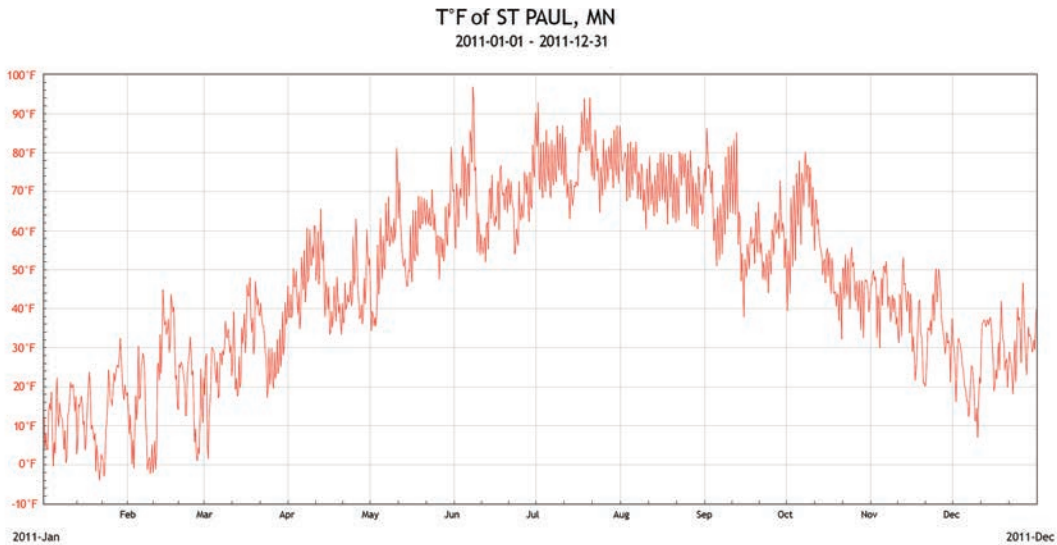

The temperature graph above shows that the outside air temperature is 70°F or below about two thirds of the year, and above this level about one third of the time. A collection storage facility in this climate would need mechanical equipment capable of providing heat to the spaces from late September through June to maintain an indoor temperature of 70°F. Cooling would be required periodically between late June and September. A good thermal envelope could be expected to flatten out wide daily temperature swings.

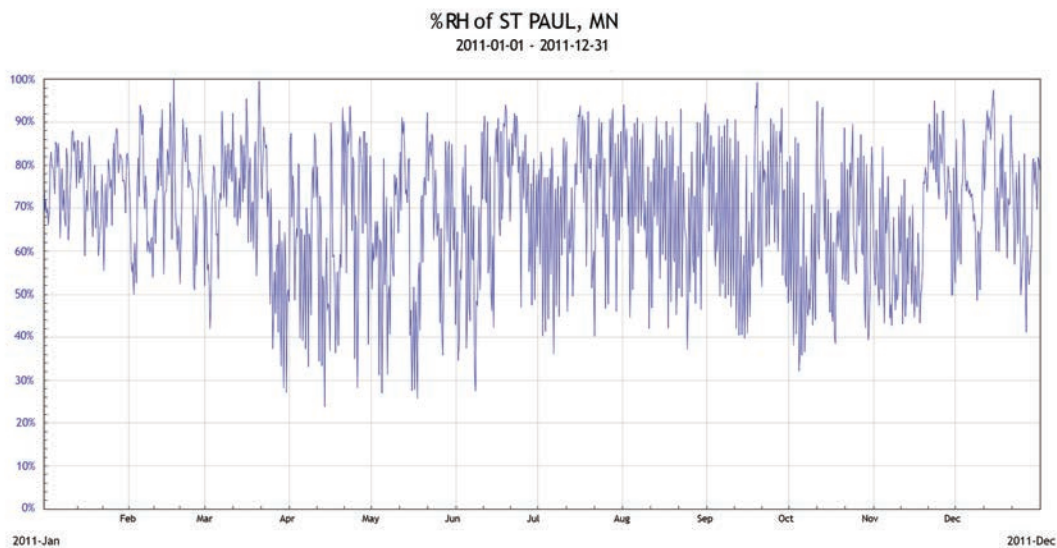

The outdoor relative humidity graph on the previous page shows wide daily swings in RH much of the year, and RH that is often above 60%. This suggests that any outside air that enters the collection storage area will be too humid most of the time. While this graph is of some interest, it does not provide a clear idea of how much dehumidification will be required and when it is needed, as relative humidity alone does not indicate how much moisture is in the air. Relative humidity illustrates the ratio of how much moisture is present relative to how much moisture the air can hold at a given temperature. To judge how much you should dehumidify and when, you need to know how much moisture is actually present in the outside air (the absolute humidity of the outside air) versus the amount of moisture you want in the indoor air (the desired absolute humidity of the storage area).

The dew point temperature is an indirect expression of the absolute humidity of the air (see Section 5B, Understanding the Moisture Content of the Air for more information). A comparison of the outside air dew point temperature and the desired storage area dew point temperature illustrates the need for humidification and dehumidification. For this example we used a 50°F dew point temperature.

The outside air dew point temperature of St. Paul MN seen in the graph below shows that the air outside is below the desired 50°F dew point temperature two-thirds of the time (January through mid-June and October through December). Any outside air brought into the storage space during this time will need humidification. The dew point temperature is above 50°F from mid-June through September, during which time dehumidification may be required.

Note that redefining our desired indoor conditions to 70°F and 35% RH (with the dew point temperature at 41°F) would somewhat reduce the need to humidify.

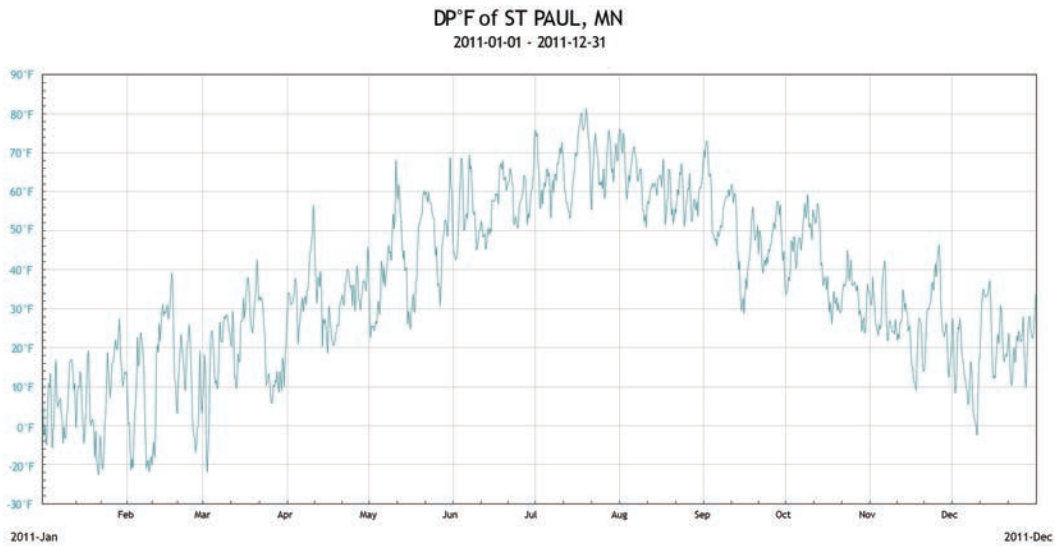

# HVAC System Documentation Worksheet - Part 1

Herzog/Wheeler & Associates LLP, St. Paul, MN – Peter Herzog

Symbol	Checklist of Space Features
LTS	Lights
S	Manual Light Switch
T	Temperature Control Sensor
H	Humidity Control Sensor
Hr	Heating Device - Radiator
Hp	Heating Device - Portable Heater
Hum	Portable Humidifier
D-Hum	Portable Dehumidifier
W	Workstation
Ext	Exterior Envelope
EXHT	Exhaust Location
LOG	Logger Location

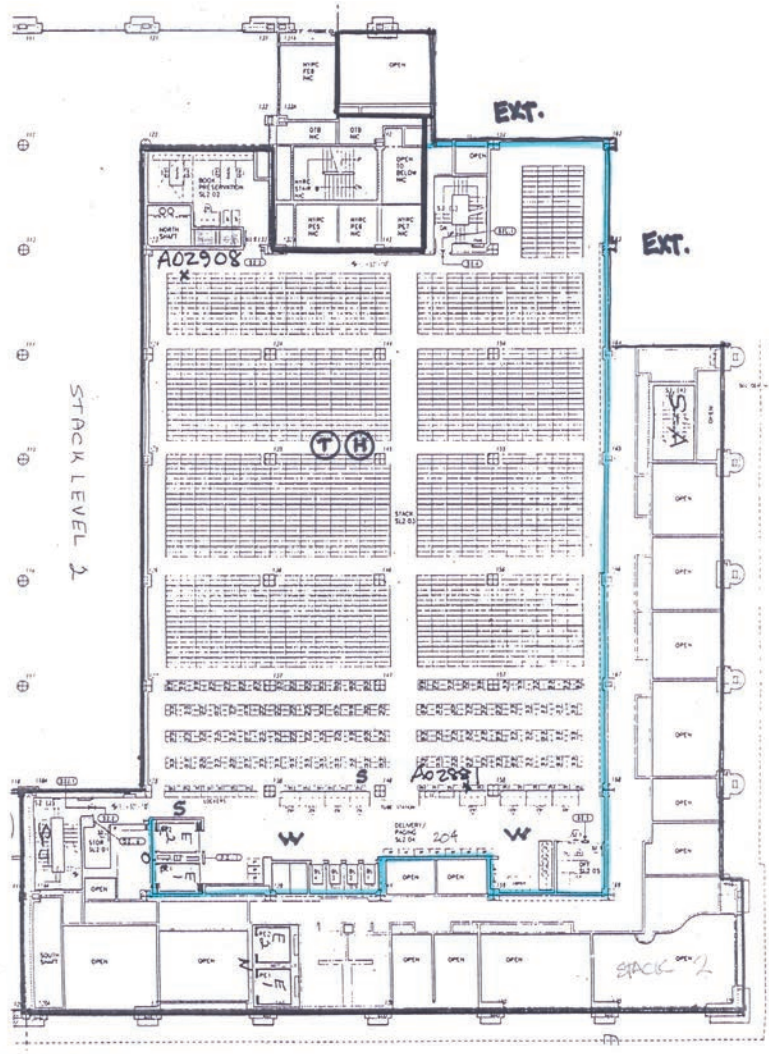

Copy of Architectural Plan of Space(s) Served by the HVAC System

From mechanical HVAC plans (AHU Schedules)

## Design air leaving cooling coil

Dry Bulb 51°F Wet Bulb 50.5°F Dew Point Temperature 50°F

% Outside Air (outside air / total air)  $\frac{3000}{50,890} = 6\%$

# HVAC System Documentation Worksheet - Part 2

Herzog/Wheeler & Associates LLP, St. Paul, MN – Peter Herzog

Symbol	Checklist of System Components
	Spaces Served
	Supply Air Diffusers
VAV	Supply Air Variable Air Volume (VAV) Boxes
H	Terminal Heat
SA	Supply Air Ducts
AHU	Air Handling Unit (AHU)
RA	Return Air Path (Plenum, Ducts)
RF	Return Air Fan
Relief	Relief Air Path - Duct to Outside
	Relief Air Path - Exfiltration from Spaces
OA	Outside Air Duct
EXHT	Exhaust Location

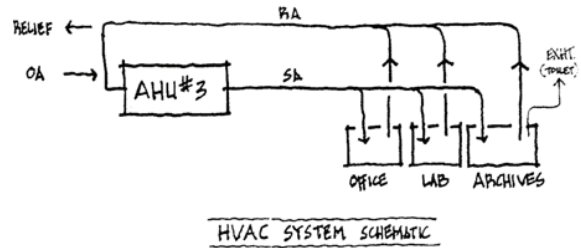

HVAC SYSTEM SCHEMATIC

Symbol	Checklist of AHU Components
OAD	Outside Air Damper
RAD	Return Air Damper
F <sub>1</sub>	Filter - Prefilter
F <sub>2</sub>	Filter - Filter
F <sub>3</sub>	Filter - Chemical Filter
C <sub>1</sub>	Cooling/Dehumidification Coil - DX
C <sub>2</sub>	Cooling/Dehumidification Coil - Chilled Water
DD	Desiccant Dehumidification
H <sub>1</sub>	Heating Coil - Steam
H <sub>2</sub>	Heating Coil - Hot Water
H <sub>3</sub>	Heating Coil - Electricity
HUM	Humidifier
SF	Supply Fan
RF	Return Fan
T	Temperature Control Sensor
H	Humidity Control Sensor

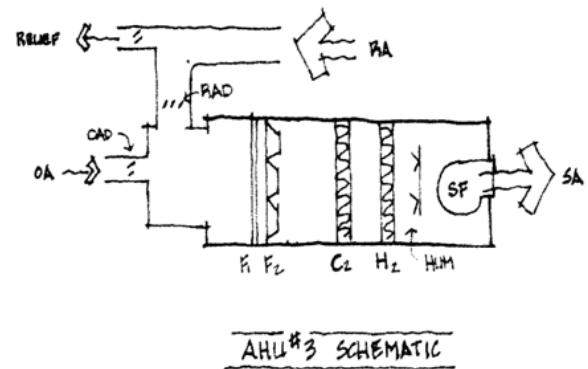

AHU#3 SCHEMATIC

# HVAC System Documentation Worksheet - Part 3

Herzog/Wheeler & Associates LLP, St. Paul, MN – Peter Herzog

Symbol	Checklist of System Components
	Spaces Served
	Supply Air Diffusers
VAV	Supply Air Variable Air Volume (VAV) Boxes
H	Terminal Heat
SA	Supply Air Ducts
AHU	Air Handling Unit (AHU)
RA	Return Air Path (Plenum, Ducts)
RF	Return Air Fan
Relief	Relief Air Path - Duct to Outside
	Relief Air Path - Exfiltration from Spaces
OA	Outside Air Duct
EXHT	Exhaust Location

Symbol	Checklist of AHU Components
OAD	Outside Air Damper
RAD	Return Air Damper
F <sub>1</sub>	Filter - Prefilter
F <sub>2</sub>	Filter - Filter
F <sub>3</sub>	Filter - Chemical Filter
C <sub>1</sub>	Cooling/Dehumidification Coil - DX
C <sub>2</sub>	Cooling/Dehumidification Coil - Chilled Water
DD	Desiccant Dehumidification
H <sub>1</sub>	Heating Coil - Steam
H <sub>2</sub>	Heating Coil - Hot Water
H <sub>3</sub>	Heating Coil - Electricity
HUM	Humidifier
SF	Supply Fan
RF	Return Fan
T	Temperature Control Sensor
H	Humidity Control Sensor

From mechanical HVAC plans (AHU Schedules)

**Design air leaving cooling coil**

Dry Bulb \_\_\_\_\_ Wet Bulb \_\_\_\_\_

Dew Point Temperature \_\_\_\_\_

% Outside Air (outside air / total air) \_\_\_\_\_ %

## Sustaining Cultural Heritage Collections

**Application Deadline:** Generally mid-November of each year

**Visit:** <http://www.neh.gov/grants/guidelines/SCHC.html> for more information

The National Endowment for the Humanities Sustaining Cultural Heritage Collections program helps cultural institutions meet the complex challenge of preserving large and diverse holdings of humanities materials for future generations by supporting preventive conservation measures that mitigate deterioration and prolong the useful life of collections.

To preserve and ensure continued access to collections in libraries, archives, museums, and historical organizations across the country, institutions must implement preventive conservation measures. These activities include managing temperature, relative humidity, light and pollutants in collection spaces; providing protective storage enclosures and systems for collections; and safeguarding collections from theft, natural and man-made disasters.

As they strive to be effective stewards of humanities collections, cultural institutions are increasingly interested in sustainable preservation strategies, which balance preservation effectiveness, cost, and environmental impact. A growing body of research suggests that institutions can develop effective, energy-efficient, and environmentally sensitive preservation measures, particularly for managing the environmental conditions under which collections are stored or exhibited. NEH therefore invites proposals that explore and implement sustainable preservation measures that are designed to mitigate the greatest risks to collections rather than to meet prescriptive targets.

To help institutions develop sound preventive conservation projects, NEH encourages collaborative and interdisciplinary planning, which is important for identifying sustainable strategies. Such planning should include consideration of the following factors: the nature of the materials in a collection; the performance of the building, its envelope, and its systems in moderating internal environmental conditions; the capabilities of the institution; the nature of the local climate and the effects of climate change; the cost-effectiveness and energy efficiency of various approaches to preventive conservation; and the project's impact on the environment.

SUSTAINING CULTURAL HERITAGE COLLECTIONS OFFERS TWO KINDS OF AWARDS:

### **Planning Grants of up to \$40,000**

To help an institution develop and assess preventive conservation strategies, grants will support planning projects, which may encompass such activities as site visits, planning sessions, environmental monitoring, testing, project-specific research, and preliminary designs for implementation projects. Planning grants focused on exploring sustainable preventive conservation strategies are especially encouraged. These grants might be used to:

- Examine passive and low-energy alternatives to conventional energy-intensive mechanized systems for managing environmental conditions;

- Analyze existing mechanical systems and the performance characteristics of buildings and building envelopes to develop a plan for improved operation, effectiveness, and energy efficiency; or
- Evaluate the effectiveness of preventive conservation strategies previously implemented, including energy-efficient upgrades to existing systems and performance upgrades to buildings and building envelopes.

### **Implementation Grants of up to \$400,000**

Implementation projects should be based on planning which is specific to the needs of the institution and its collections within the context of its local environment. It is not necessary to receive an NEH planning grant to be eligible for an implementation grant. Planning could be supported by NEH, other federal agencies, private foundations, or an institution's internal funds. These grants might be used to:

- Manage interior relative humidity and temperature by passive methods such as creating buffered spaces and housing, controlling moisture at its sources, or improving the thermal and moisture performance of a building envelope;
- Install or re-commission heating, ventilating, and air conditioning systems;
- Install storage systems and re-house collections;
- Improve security and the protection of collections from fire, flood, and other disasters;
- Upgrade lighting systems and controls to achieve energy efficiency and levels suitable for collections.

Implementation grants may also cover costs associated with renovation required to implement preventive conservation measures. Because Sustaining Cultural Heritage Collections grants may not fund new construction, the costs of installing climate control, security, and fire protection systems in a building under construction are not eligible. However, grants may support the purchase of storage furniture and the rehousing of collections that will be moved into a new building.

### **Preservation Assistance Grants (PAG) for Smaller Institutions**

**Application Deadline:** Generally early May of each year

**Visit:** <http://www.neh.gov/grants/guidelines>

Preservation Assistance Grants help small and mid-sized institutions—such as libraries, museums, historical societies, archival repositories, cultural organizations, town and county records offices, and colleges and universities—improve their ability to preserve and care for their humanities collections. Small and mid-sized institutions that have never received an NEH grant are especially encouraged to apply. Outright grants of up to \$6,000 will be awarded. Cost sharing is not required in this program. If eligible expenses are more than \$6,000, an applicant may cover the difference and show this as cost sharing in the project's budget. All grants are awarded for a period of eighteen months, although a grantee may complete a project in a shorter period of time.

Applicants must draw on the knowledge of consultants whose preservation skills and experience are related to the types of collections and the nature of the activities that are the focus of their projects.



Within the conservation field, for example, conservators usually specialize in the care of specific types of collections, such as objects, paper, or paintings. Applicants should therefore choose a conservator whose specialty is appropriate for the nature of their collections. Similarly, when assessing the preservation needs of archival holdings, applicants must seek a consultant specifically knowledgeable about archives and preservation. Because the organization and the preservation of archival collections must be approached in tandem, an archival consultant should also provide advice about the management and processing needs of such holdings as part of a preservation assessment that includes long-term plans for the arrangement and description of archival collections.

### **Preservation Assistance Grants may be used for:**

- General preservation assessments—engage a conservator, preservation librarian, archivist, or other appropriate consultant to conduct a general preservation assessment and help draft a long-range plan for the care of humanities collections.
- Consult with professionals to address a specific preservation issue, need, or problem—hire a consultant to help with disaster preparedness and response plans; establishment of environmental monitoring programs or integrated pest management programs; **develop plans for improving environmental conditions or security or fire protection for collections; etc.**
- Purchase of storage furniture and preservation supplies—if you have completed a preservation assessment or consulted with an appropriate professional you may request funds to purchase storage furniture and supplies.
- **Purchase of environmental monitoring equipment for humanities collections—Applicants may purchase environmental monitoring equipment. If the institution’s staff does not have experience using the equipment, the application should include a request for training in the use and installation of the equipment and the interpretation of the monitoring data.**
- Education and training—request support to send staff members who work with humanities collections to workshops and training courses addressing both preservation and access topics.

Applicants may also hire a consultant to conduct on-site training for staff and volunteers. On-site workshops may be tailored to meet specific needs and holdings of the institution. Staff and volunteers from neighboring organizations may also be invited to participate in on-site workshops.

Workshops could focus on such topics as the following:

- preservation and care of humanities collections (often offered by collection type, e.g., textiles, paintings, photographs, archival records, manuscripts, and books),
- methods and materials for the storage of collections,
- **environmental monitoring programs,**
- disaster preparedness and response,
- best practices for cataloging art and material culture collections,

- proper methods for the arrangement and description of archival collections,
- best practices for sustaining digital collections,
- standards for digital preservation, and
- care and handling of collections during digitization.

Applicants may combine two or more elements of the project types listed above in a single application. For example, an applicant may request funds for a consultant to conduct a preservation assessment and an on-site preservation workshop for the institution's staff. In such cases, the consultant's letter of commitment should describe both the assessment and the on-site workshop.

NEH grants may support consultant fees, workshop registration fees, travel and per diem expenses, and the costs of purchasing and shipping preservation supplies and equipment.

### Additional Funding Opportunities:

- The Institute of Museum and Library Services has many grant programs available which you can read about at: <http://www.imls.gov/applicants/name.shtml>
- LYRASIS provides an excellent list of funding resources on its website: <http://www.lyrasis.org/Preservation/Resources%20and%20Publications/Funding%20Resources%20for%20Preservation.aspx>

## IPI's Environmental Management Products

The Image Permanence Institute (IPI) has formulated a new definition of the preservation environment and has developed tools and procedures that allow cultural institutions to understand and improve long-term preservation of collections. IPI's view is based on decades of research into accelerated-aging, equilibration rates, image stability, the effects of pollution, and material decay in general. IPI has put its research into practice at hundreds of institutions in the US and abroad, most significantly at the Library of Congress, the National Archives & Records Administration, the New York Public Library, and the National Museum of Denmark. IPI has developed the best research-based tools available to cultural institutions for monitoring, documenting, and analyzing the storage environment.



To help preservation staff in cultural institutions understand the impact of the environment on their collections and evaluate the potential risk of deterioration, IPI developed Preservation Metrics™. These metrics have become the cornerstone of IPI's approach to sustainable preservation practices (see Section 6B, "Use IPI's Preservation Metrics to Analyze the Risk of Decay" for more information).

## Software

IPI's first environmental data management and analysis software program was Climate Notebook® which was tested during two NEH-funded field trials in over 200 institutions between 1997 and 2004. Climate Notebook was an extremely effective tool for risk analysis but lacked the ability to easily organize and search data by location or to document the wide range of information associated with storage locations. To meet these needs, IPI developed a web-based data management system called MyClimateData in partnership with the National Museum of Denmark and the Library of Congress. MyClimateData was a robust tool, particularly for large institutions, because it centralized data within a searchable database and made it easier for staff throughout an institution to access up-to-date and complete environmental data. This site was tested by a group of 15 museum and library research partners during an IMLS-funded research and development project in 2008-2009. At the same time, IPI developed a second web-based program called PEMdata to accompany the 2007 release of the PEM2® datalogger. This free website streamlined the environmental management, giving users a simple way to store and graph data and to understand the effect of the environment on their collections.

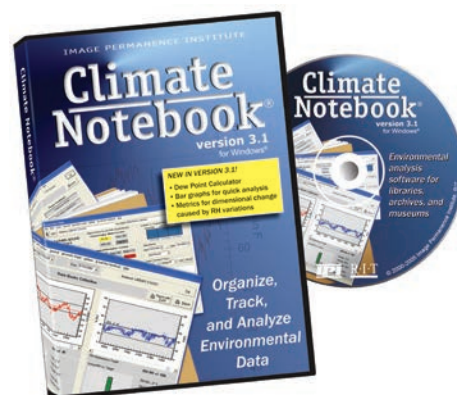

Based on user response to these three data management products, IPI focused on developing a web application that would assimilate the strengths of each into a single, unified platform. Released in May 2012, eClimateNotebook™ replaced Climate Notebook, MyClimateData and PEMdata. More information on this product is included on the next page.

IPI also developed the Dew Point Calculator, a web tool designed to demonstrate the relationship between temperature, relative humidity, and dew point. This device is available at [www.dpcalc.org](http://www.dpcalc.org).

## Hardware

IPI's original Preservation Environment Monitor® (PEM) was developed between 1995 and 2000 with funding from the NEH Division of Preservation and Access. IPI's goal was to design and demonstrate an electronic temperature and humidity recording device specifically for preservation use in cultural institutions that would facilitate the collection and interpretation of environmental data. Production of the original PEM ended in December 2007 when IPI introduced the PEM2®, designed with easy USB upload capabilities. Both loggers have highly accurate temperature and RH sensors and come with a five-point NIST-traceable calibration certificate. The PEM2 can hold more than 20 years' worth of data and battery life is typically 10 years or longer.

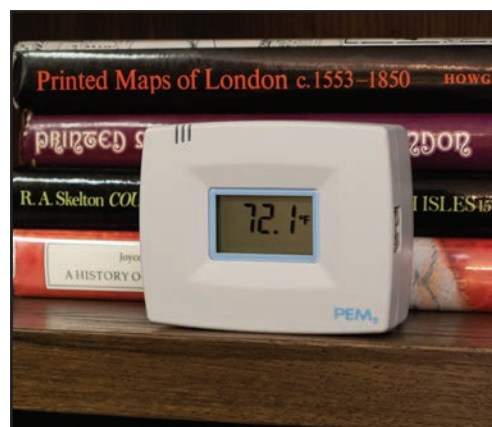

## Introducing IPI's latest product – eClimateNotebook™

eClimateNotebook™ combines ease of use, powerful analysis, and extensive data management features into one web-based product. All the best features of our previous software tools are included. Some of the benefits of using eClimateNotebook include:

- All system upgrades—both features and functionality—are automatically available to subscribers at the appropriate level.
- One web-based data management and analysis site allows users to easily transition to the next level of the eCNB system.
- Institutional users have immediate access to the same data from any computer with a web connection. This makes it easy to share information among collections care, facilities management, and administrators.
- Fast and reliable data upload and analysis features save staff time.
- Basic and Professional levels allow universal logger import.
- Compatible with both PC and Mac platforms.
- Technical support is included at no extra cost.
- Safe and secure data storage with daily backups.

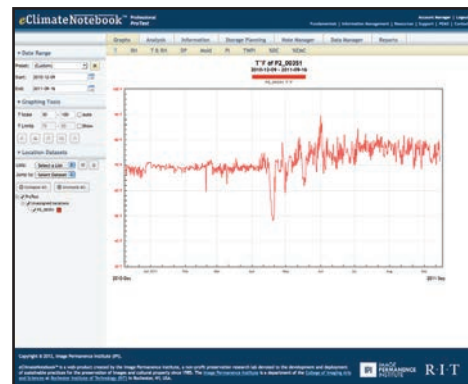

Risk Summary	
Natural Aging	RISK
Mold Risk	GOOD
Metal Corrosion	RISK
Mechanical Damage	OK

THE FOLLOWING ECLIMATENOTEBOOK SUBSCRIPTION LEVELS ARE AVAILABLE:

### eClimateNotebook—Free Level

The Free level is best for smaller institutions with limited resources and a small number of monitored locations. This level can be used with the DBF files from Climate Notebook desktop software and data from both the original PEM and the PEM2 loggers. Users will have easy access to outdoor weather data, the Dew Point Calculator, interactive graphs with limit lines, IPI's Preservation Metrics™, and statistics to help with your analysis. You can compare up to 3 locations on graphs of environmental data, Preservation Metrics and in Risks & Metrics and Statistics tables.

Free                      1 institutional user limit                      3 location datasets limit                      \$0/year

### eClimateNotebook—Basic and Basic Plus Level

The two Basic levels will meet the needs of most small to medium institutions. The Basic levels include all the features in the Free level plus automated reports and the ability to import data from a wide range of commonly used dataloggers. You can compare up to 8 locations on graphs of environmental data,

Preservation Metrics and in Risks & Metrics and Statistics tables.

Basic	5 institutional users limit	10 location datasets limit	\$120/year
Basic Plus	10 institutional users limit	25 location datasets limit	\$300/year

### **eClimateNotebook—Professional and Professional Plus Levels**

The two Professional levels add a number of key management functions needed by medium to large institutions. Features include a multi-level hierarchy of storage locations and an associated information database with both default and custom fields. These levels include additional compare features, customizable material selections, and extensive search options. Users can easily evaluate the preservation quality of each monitored location and determine which areas are best suited to particular materials. The Professional levels has systems for incorporating floor plans and photographs, and for incidents and activities such as leaks and storage upgrades. Both basic and customizable reports are available.

Professional	20 institutional users limit	50 location dataset limit	\$600/year
Professional Plus	Unlimited institutional users	Unlimited location datasets	\$900/year

To evaluate the features in the Basic or Professional levels of eCNB, visit:  
<https://www.eclimatenotebook.com> and click on either Basic Demo or Professional Demo.

You can sign up for the Free level of eCNB at <https://www.eclimatenotebook.com/plans>.

# Index

## A

Air Handling Unit (AHU) 26–31, 41–43, 75

## B

Building Classifications 20–26

Building Management Systems 34, 54

## C

Climate 16–20, 92–102

Cooling 25, 27–29, 43, 51, 73–74, 76

## D

Data Analysis 53–63

Data Collection 33–34

Datalogger 34, 36–38, 53, 88, 110

Decay 10–15, 54

    Biological Decay 11

    Chemical Decay 10–11

    Mechanical Decay 11

Dehumidification 27, 46–47, 51, 59–62, 76, 87, 92–105

Dew Point 8, 46–52, 59–63

## E

Energy Consumption 28–31

Energy Savings 73–80, 88

Environmental Management Team 31–32, 64–73

Equilibration 13–15, 84

## H

Heat Loads 44

Heating 21–22, 27–29, 43–44, 73–74, 76

Humidification 24, 26, 28, 30, 77

HVAC System Documentation 69, 103–105

HVAC Zones 39–43

Hygrometer 35

Hygrothermograph 36

## L

Light 22, 25, 30, 44, 62, 74, 77

Local Climate 16, 92–102

## M

Material Types

    Composite 9

    Inorganic Materials 9–10

    Organic Materials 9

Mechanical Damage 11, 56. *See also* Mechanical Decay

Mechanical System Documentation 38–46, 103–105

Mechanical System Performance 20–31, 59–63, 69–73, 78–79

Metal Corrosion 11, 58. *See also* Chemical Decay

Moisture 44–45, 74

Moisture Equilibration 14–15

Mold Risk 11, 57. *See also* Biological Decay

Monitoring Tools 35–38

## N

Natural Aging 55. *See also* Chemical Decay

## O

Optimal Storage Environment 68–72

Outdoor Data 18–20, 93–102

Outside Air 28, 78

## P

Preservation Metrics 54–58

Psychrometer 35

## R

Relative Humidity (RH) 8, 13, 45, 49–50, 85–87

## S

Schematic Diagrams 41–43, 104

Setbacks 62, 79–80

Shutdowns 79–80

## T

Temperature 8, 12–13, 74, 85–87

Thermal Equilibration 13–14

Time-weighted Preservation Index (TWPI) 55, 82

## V

Ventilation 21–23, 25–26, 32, 45, 91

## About the Image Permanence Institute

The Image Permanence Institute (IPI) is a recognized world leader in the development and deployment of sustainable practices for the preservation of images and cultural property. IPI accomplishes this through a balanced program of research, education, products and services that meet the needs of individuals, companies, and institutions.

IPI is a nonprofit, university-based laboratory devoted to preservation research. It is the world's largest independent laboratory with this specific scope. IPI was founded in 1985 through the combined efforts and sponsorship of the Rochester Institute of Technology and the Society for Imaging Science and Technology. Funding for IPI's preservation research and outreach efforts has come primarily from the National Endowment for the Humanities, the Institute of Museum and Library Services, and the Andrew W. Mellon Foundation. IPI provides information, consulting services, practical tools and preservation technology to libraries, archives, and museums worldwide. The imaging and consumer preservation industries also use IPI's consulting, testing and educational services.

Visit our website at [www.imagepermanenceminstitute.org](http://www.imagepermanenceminstitute.org) to learn more about IPI's research, education, and outreach activities.

IPI's research and educational activities are made possible through generous support from the Andrew W. Mellon Foundation, the Institute for Museum and Library Services, and the National Endowment for the Humanities



Image Permanence Institute  
Rochester Institute of Technology  
70 Lomb Memorial Drive  
Rochester, NY 14623-5604  
[www.imagepermanenceminstitute.org](http://www.imagepermanenceminstitute.org)  
(585) 475-5199